

Product Description

The SL200X pressure reducing valve is an intelligent valve that uses the energy of the medium to regulate and control the pressure of the line. The 200X pressure reducing valve is used for domestic water supply, fire water supply and other industrial water supply systems. By adjusting the pressure reducing pilot valve, the outlet pressure of the main valve can be adjusted. The outlet pressure is not changed by the inlet pressure and the change of the inlet flow. The outlet pressure is safely and reliably maintained at the set value, and the set value can be adjusted as needed to achieve the purpose of decompression. The valve has precise decompression, stable performance, safety and reliability, and convenient installation and adjustment.

External Structure

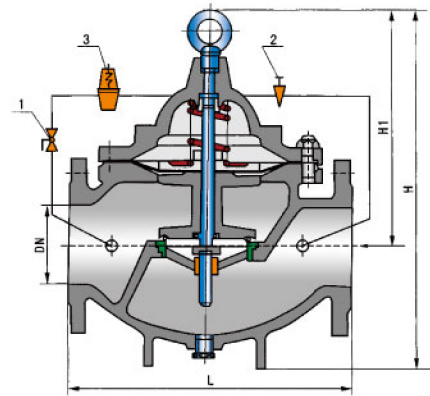

1. Float ball pilot valve 2. ball valve 3. Needle valve

Typical Installation Diagram

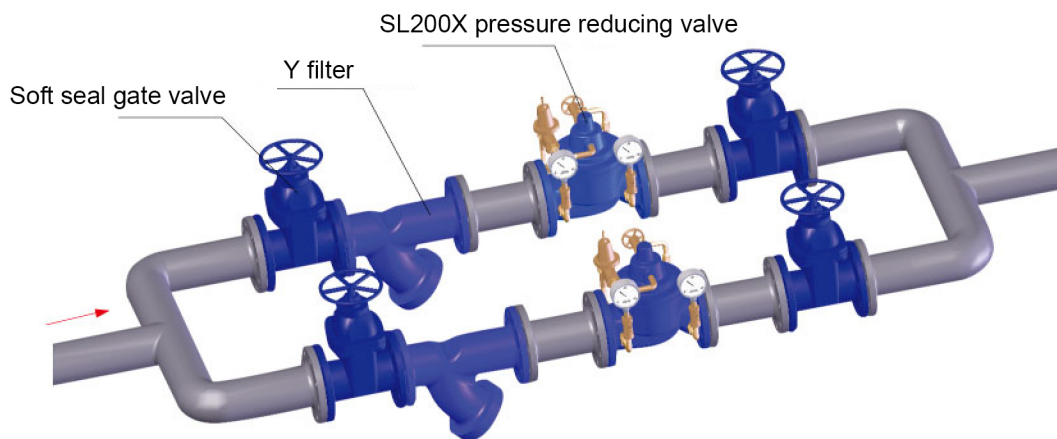

Main Dimensions													unit:(mm)
DN	40	50	65	80	100	125	150	200	250	300	350	400	450
L	200	203	216	241	292	330	356	495	622	698	787	914	978
H1	210	210	215	245	305	365	415	510	560	658	696	735	735
H	395	395	405	430	510	560	585	675	730	760	840	910	910