

# COVNA®

— VALVE —

ISO9001 CE RoHS  

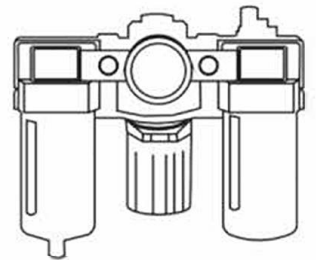
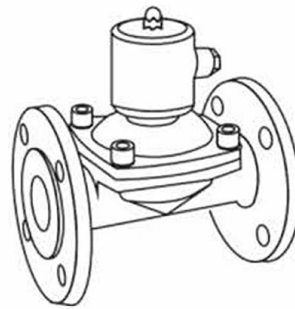
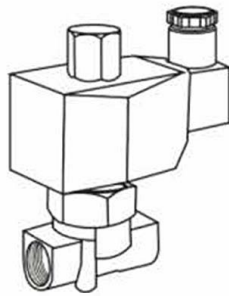
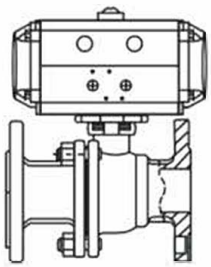

## OPERATING MANUAL



**Introduction**

Ultra Low Torque, Elegant, Durable, Corrosion Resistance

Full Flow, PTFE Ball sealing, Low Torque Can Use the Handle Regulating Valve Seat Tightness Released By The Central Section Is Still Intact, Valves, Replaceable To Provide Supplementary Platform Embedded Copper Nut Products Convenient Automatic Actuator

**Pneumatic Actuator**

|                    |   |
|--------------------|---|
| Double acting      | Air to open, air to close, air supply failure to keep the current position                                      |
| Single Acting N/C  | Air to open, interrupt air to close, air failure to close   |
| Single Acting N/O  | Air to close, interrupt air to open, air failure to open  |
| Optional accessory | Reversing solenoid valve, limit switch box, air filter reducing valve, positioner, handle manual, lock up valve |



**Technical Parameters**

| Body            |   | Valve components  |  |
|-----------------|---|-------------------|--|
| Nominal Size    | DN15~DN50   | Seat Material     | EPDM   |
| Body Material   | Plastic UPVC  | Core Material     | Plastic UPVC   |
| Connection Type | Double union  | Stem Material     | SS304, SS410   |
| Pressure Rating | PN1.0MPa PN1.6MPa                                     | Applicable Medium | Water, Liquids, Gas, Oil, Powder, Steam, Acid-base Corrosive Medium. |
| Structure type  | Floating ball core<br>3 way L-type/ T-type ball valve |                   |  |

T-Pattern Flow Direction Diagram

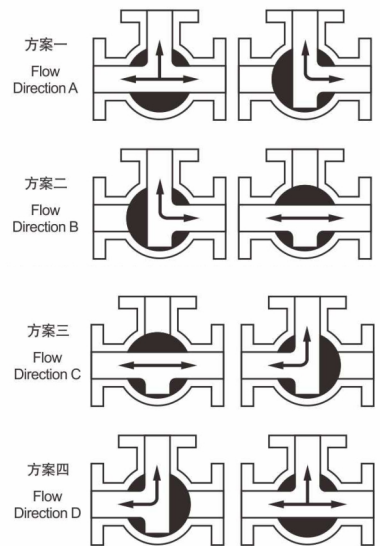

L-Pattern Flow Direction Diagram

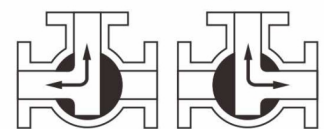

**Quintine Size drawing**

UNIT: mm

| MEDLE    | DN15 | DN20 | DN25 | DN32   | DN40   | DN50 |
|----------|------|------|------|--------|--------|------|
| G        | 1/2" | 3/4" | 1"   | 1-1/4" | 1-1/2" | 2"   |
| d        | 14   | 22   | 25   | 25     | 38     | 38   |
| D        | 20   | 25   | 32   | 40     | 50     | 63   |
| D1       | 30   | 36   | 45   | 55     | 64     | 77   |
| L1       | 22   | 24.5 | 28   | 32     | 35     | 38   |
| L        | 137  | 172  | 200  | 208    | 240    | 246  |
| H        | 53   | 65   | 68   | 68     | 92     | 92   |
| Actuator | AT52 | AT52 | AT63 | AT63   | AT75   | AT83 |

**Maintenance**

- Tightening the seal between the valve and the actuator:  
Remove the four bolts underneath the actuator. Separate the actuator from the valve.  
Tighten the nut on the top of the valve body.  
Place the actuator back on the valve and screw everything back into place.
- Tightening the seals between the valve and the inlet/outlet ports:  
Remove the torque bolts and check for any debris or damage to the gaskets.  
Use a torque wrench or other consistent method of tightening the torque bolts to reconnect the inlet and outlet ports.

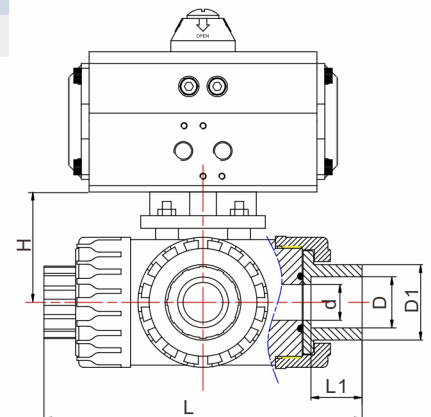

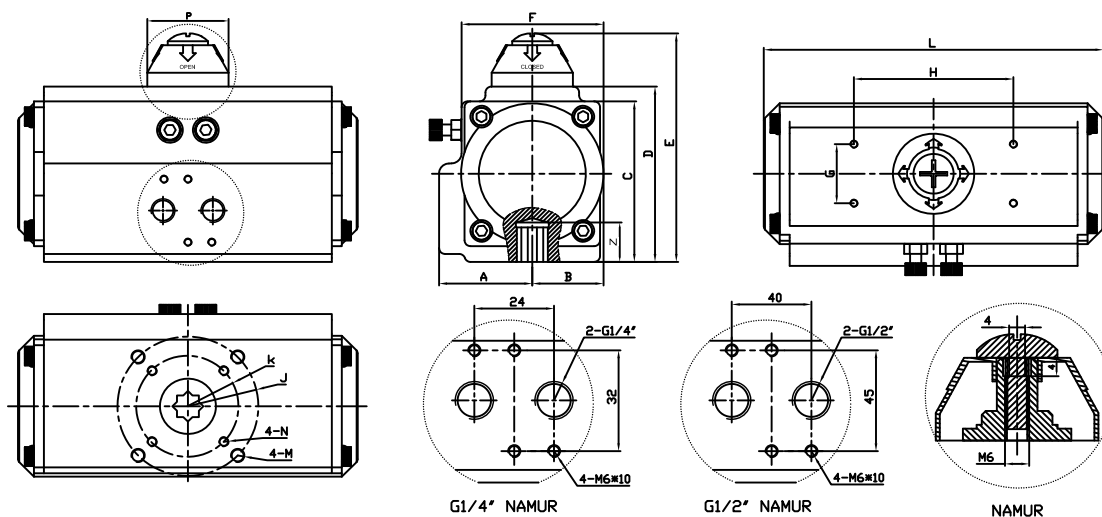

**Introduction**

1. Operating media: Dry or lubricated air, or the non-corrosive gases The maximum particle diameter must less than 30 u m
2. Air supply pressure: The minimum supply pressure is 2.5 Bar The maximum supply pressure is 8 Bar
3. Operating temperature: Standard:  $-20^{\circ} \text{ c} \sim +80^{\circ} \text{ c}$  Low temperature:  $-35^{\circ} \text{ c} \sim +80^{\circ} \text{ c}$  High temperature:  $-15^{\circ} \text{ c} \sim M50^{\circ} \text{ c}$
4. Travel adjustment: Have adjustment range of  $\pm 5^{\circ}$  for the rotation at  $0^{\circ}$  and  $90^{\circ}$

**Outline Size drawing**

| MODEL | A    | B    | C     | D     | E     | F     | G  | H   | J    | K    | N      | M      | L   | P  | Z  | Air Hole    |
|-------|------|------|-------|-------|-------|-------|----|-----|------|------|--------|--------|-----|----|----|-------------|
| AT52  | 30   | 42.5 | 65.5  | 72.4  | 92.5  | 50.5  | 30 | 80  | Ø36  | Ø50  | M5×8   | M6×10  | 150 | 42 | 14 | NAMUR G1/4" |
| AT63  | 36   | 47   | 81    | 88.5  | 98.5  | 69.5  | 30 | 80  | Ø50  | Ø70  | M6×10  | M8×13  | 171 | 42 | 18 | NAMUR G1/4" |
| AT75  | 42.5 | 53   | 93    | 100   | 120   | 78    | 30 | 80  | Ø50  | Ø70  | M6×10  | M8×13  | 186 | 42 | 18 | NAMUR G1/4" |
| AT83  | 46.5 | 57   | 98.5  | 109.7 | 129.5 | 86    | 30 | 80  | Ø50  | Ø70  | M6×10  | M8×13  | 206 | 42 | 21 | NAMUR G1/4" |
| AT92  | 50   | 58   | 106   | 117   | 137   | 90    | 30 | 80  | Ø50  | Ø70  | M6×10  | M8×13  | 265 | 42 | 21 | NAMUR G1/4" |
| AT105 | 57.5 | 64   | 122.5 | 135   | 155   | 104.5 | 30 | 80  | Ø70  | Ø102 | M8×13  | M10×16 | 272 | 42 | 27 | NAMUR G1/4" |
| At125 | 67.5 | 74.5 | 145.5 | 157   | 177   | 120.5 | 30 | 80  | Ø70  | Ø102 | M8×13  | M10×16 | 304 | 60 | 27 | NAMUR G1/4" |
| AT140 | 75.5 | 75.5 | 161   | 174   | 194   | 125   | 30 | 80  | Ø102 | Ø125 | M10×16 | M12×20 | 395 | 60 | 32 | NAMUR G1/4" |
| AT160 | 87   | 87   | 184   | 198   | 228   | 143   | 30 | 80  | Ø102 | Ø125 | M10×16 | M12×20 | 462 | 60 | 32 | NAMUR G1/4" |
| AT190 | 103  | 103  | 216   | 232   | 262   | 172   | 30 | 130 | Ø102 | Ø140 | M10×16 | M16×25 | 520 | 85 | 40 | NAMUR G1/4" |
| AT210 | 113  | 113  | 235.5 | 257   | 287   | 194   | 30 | 130 | Ø102 | Ø140 | M10×16 | M16×25 | 538 | 85 | 40 | NAMUR G1/4" |
| AT240 | 130  | 130  | 235.5 | 292   | 322   | 230   | 30 | 130 |      | Ø165 |        | M20×30 | 592 | 90 | 50 | NAMUR G1/4" |
| AT270 | 147  | 147  | 235.5 | 331   | 361   | 253   | 30 | 130 |      | Ø165 |        | M20×30 | 713 | 90 | 50 | NAMUR G1/2" |
| AT300 | 161  | 168  | 235.5 | 354   | 384   | 290   | 30 | 130 | Ø165 | Ø215 | M20×30 | M20×30 | 771 | 90 | 50 | NAMUR G1/2" |

**Common faults and inspection, troubleshooting**

| Failure Phenomenon           | Inspection Items   | Solution   |
|------------------------------|--|--|
| Pneumatic Valve Can Not Move | The electromagnetic valve is normal, Coil is burned, electromagnetic valve Is stuck being stolen | Solenoid valve replacement, Replacement coils, remove stolen Property. |
|                              | A separate air supply pneumatic Actuator test check seals and Whether the cylinder is damaged.   | Replace a bad ring and cylinder.                                       |
|                              | There are impurities in the spool Valve stuck.   | Remove impurities, replace Damaged parts.                              |
|                              | the handle in a manual hand motor location.  | Interchange  |
| Slow Motion, Crawling        | Supply pressure is not enough.   | The increase of gas supply pressure(0.4–0.7mpa)                        |
|                              | Pneumatic actuator outputtorque is Too small.  | Increase the pneumatic actuator Production.                            |
|                              | The valve spool or valve assembly too tight.   | Re-assembly adjustments.   |
|                              | Air supply pipe plug, flow is too small.   | Exclude plug, replace the filter cartridge.                            |
| Reply Devices Without Signal | power line short circuit or open circuit.  | Maintenance of power lines.  |
|                              | reply within the cam position is not accurate.   | Adjust the cam to the correct location                                 |
|                              | Micro switch damaged.  | Replacement micro switch   |