

Characteristic: With isolated diaphragm construction to rot-proof

PTFE body for corrosion resistant

Medium: Corrosive fluid and gas, Acid, Alkali, etc.

Temperature: PTFE Seal: -20° C to 180°C

Pressure: HKPF2: 0.0Mpa~0.15Mpa NC

Port Size: 1/8", 1/4", 3/8", 1/2"

Port Thread: BSPP, BSPT, NPT, Flange

Orifice(mm): 3, 8

Voltage: DC-12V, 24V

AC-24V, 120V, 240V/60Hz; 110V, 220V/50Hz

Tolerance: ±10%

Coils: Y82B, 35VA(AC), 30W(DC), 100%ED

YD1B, 8VA(AC), 8W(DC), 100%ED

Material: Body - PTFE

Seal - PTFE

Armature Tube - Stainless Steel304

Plunger - Stainless Steel 430F

Stop - SS403F

Springs - SS 304

Shading Rings - Stainless Steel 304

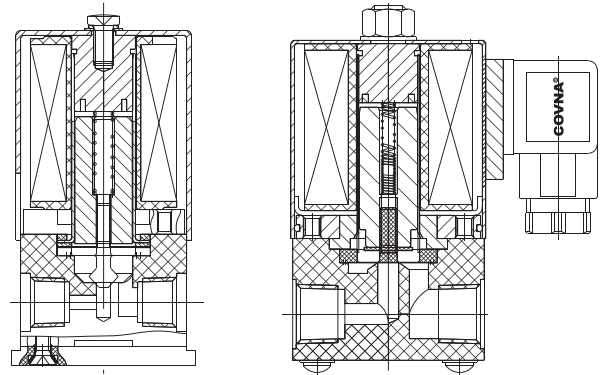

Determine Valve Body Code

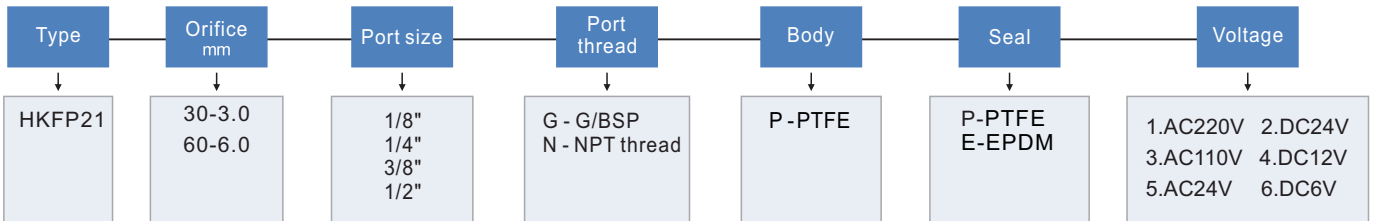

Technical Parameters

Size	Port Size	Orifice mm	Cv	Min Pressure	Max Pressure		Seals Material	Body Material	Coil
					AC(24VA)	DC(18W)			
HKFP2130XX	1/8"	3.0	0.1	0.0MPa	0.3MPa	0.3MPa	PTFE	PTFE	Y82B
					AC(20VA)	DC(28W)			YD1B
HKFP2160XX	1/4"	3.0	0.28	0.0MPa	0.15MPa	0.15MPa			YD1B
HKFP2160XX	3/8"	6.0	0.28	0.0MPa	0.15MPa	0.15MPa			YD1B
HKFP2160XX	1/2"	6.0	0.28	0.0MPa	0.15MPa	0.15MPa			YD1B
HKFP2160XX	3/4"	6.0	0.28	0.0MPa	0.15MPa	0.15MPa			YD1B
HKFP2160XX	1"	6.0	0.28	0.0MPa	0.15MPa	0.15MPa			YD1B

Outline Size Drawing

Size	A	B	C	D
HKFP21XX	90	51	102	25
HKFP21XX	90	51	102	25
HKFP21XX	90	51	102	25

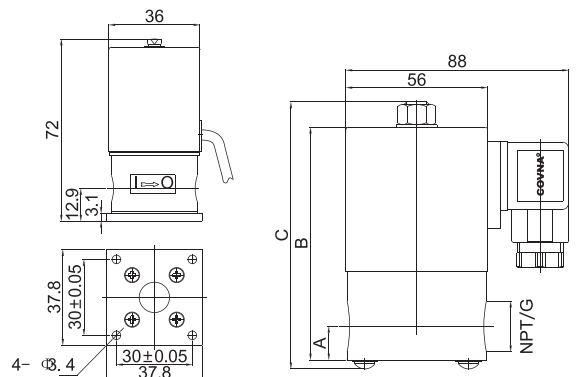

Safety instructions before starting

1. Check the compatibility of the medium used, temperature and other operating conditions with the materials and specifications of the product. It is the responsibility of the user to select the right product for the application.
2. Solenoid valves can only be used with clean liquids or gases. It is recommended to install a filter before the solenoid valve.
3. Never exceed the limits for pressure, temperature or voltage as indicated on the product and/or in the technical documentation.
4. The temperature of a solenoid valve coil can rise during operation; this is normal. Overheating will cause smoke and a burning smell. In this case, the power supply must immediately be disconnected.

▲ It is recommended to install the solenoid in vertical position with the coil facing upwards. This reduces the probability of the collection of debris in the solenoid valve.

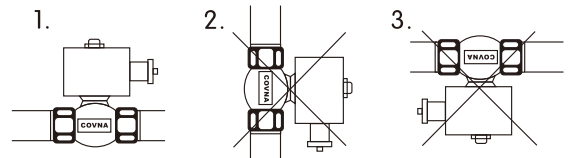

Installation Instruction

1. The solenoid valve can be used in combination with clean liquids or gases. Make sure that the pipe may contain dirt before installing the valve. It is recommended to install a filter (500 µm) before the solenoid valve.
2. Be aware of the direction of flow of the medium when installing the valve. Solenoid valves with an arrow on the housing must be connected in the indicated direction. The pipes on both sides of the valve must be securely fastened. Use a wrench for both valve and pipe while tightening to prevent unnecessary stresses in the system. The solenoid valve must be fixed via the provided connection points. Only exert force at the designated areas on the body such as the hexagon; never to the coil or armature. Avoid vibration in the pipes. Use a suitable sealant for threaded connections of the solenoid valve. Avoid the entry of thread sealing material in the valve, this can lead to malfunctioning of the valve.

Common faults and inspection, troubleshooting

Problem	Solution
Valve fails to operate	1. Check electrical supply with voltmeter. Voltage must agree with nameplate rating.
	2. Check coil with ohmmeter for shorted or opened coil.
	3. Make sure that pressure complies with nameplate rating.
The valve is sluggish or inoperative - electrical supply and pressure check out	1. Disassemble valve; clean out extraneous matter. The plunger must be free to move without binding.
	2. If a diaphragm design, check the diaphragm for tears and/or clogged or obstructed bleed hole or pilot orifice. Torn diaphragm must be replaced.
	3. Check all springs. If broken, replace.
External leakage at sleeve flange or joint between body and cover	Check that the sleeve and/or cover screws are torqued to specifications. If leakage persists, replacement of diaphragm assembly or flange O-ring may be required and/or bodies or covers with damaged sealing surfaces may have to be replaced.
External leakage at speed control device	Check O-rings for damage and replace if necessary.
Internal leakage	1. Disassemble valve, remove extraneous matter, and clean parts in a mild soap and water solution.
	2. Examine diaphragm sealing surface for dirt. Remove all foreign particles. Examine orifice for nicks. Damaged parts must be repaired or replaced.
	3. Check plunger return spring. Replace if broken.
Chatter or buzz sound when energized	1. Remove power from the coil.
	2. Inspect the plunger and sleeve for excessive wear or contamination.