



Z系列电动执行机构

Z Series Electric Actuator

[用于多回转阀门]
[For multi-turn valve]

使用说明书

User's manual



请在使用本公司产品前仔细阅读本说明书

Please read this manual carefully before using our products

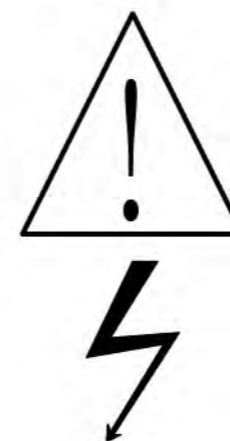

安全 Safety

该机电设备是在工业强电流的条件下使用的。在操作中，该设备上有些裸露零件带电，同时有些零件能够运动或转动，都是很危险的。因此，未经许可拆下所需的罩盖，不合理的使用，不正确的操作或不合适的维护，均会造成严重的人身伤害或损坏设备性能。为了设备的安全，必须保证：

仅允许有资质的人员对这些机械和设备进行使用。

无论何时，在上述有资质的人员对该机械和设备进行作业时，他们都应具备有这些机械和设备的操作说明书或其它产品文件，以便按说明书的要求执行。

请确认输入电压、频率及配线接点是否准确，因线序或电压引起的电机损坏，厂家不承担维修和更换。

配线进口必须做好防水处理，否则会损坏执行器，厂家不承担任何对执行器的不正当改变或维修之责任

对于使用其它厂家提供的产品或零件的错用、不正确安装、腐蚀、及未经许可的人为改动或修理，不在厂家质保服务内。

当阀门不经常工作时，应定期检查保养并进行操作，建议1次/月，时间不超过10分钟。

The electromechanical equipment is used under the condition of industrial strong current. In operation, some exposed parts of the device are charged, and some parts can move or rotate, which is very dangerous. Therefore, removing the required cover without permission, improper use, incorrect operation or improper maintenance will cause serious personal injury or damage the performance of the equipment. For the safety of the equipment, you must ensure:

Only qualified personnel should use these machines and equipment.

Whenever the above-mentioned qualified personnel work on the machinery and equipment, they should have operating instructions or other product documents for these machinery and equipment in order to perform as required by the instructions.

Please confirm whether the input voltage, frequency, and wiring contacts are accurate. The motor is not responsible for repair and replacement due to wire sequence or voltage damage to the motor.

The wiring inlet must be waterproofed, otherwise the actuator will be damaged, and the manufacturer will not bear any responsibility for improper alteration or repair of the actuator.

For the misuse, incorrect installation, corrosion, and unauthorized modification or repair of products or parts provided by other manufacturers, they are not covered by the manufacturer's warranty service.

When the valve works infrequently, it should be regularly checked and maintained, and it is recommended to operate it once a month for less than 10 minutes.

一：产品概述 / Product description

Z系列执行器，是阀门实现开启、关闭、调节控制的驱动设备。本系列执行器具有功能全、性能可靠、控制系统先进、体积小、重量轻、使用维护方便等特点。

Z系列执行器适用于启闭件做直线运动的阀门，如闸阀、截止阀、隔膜阀、柱塞阀、截流阀、水闸门等，可用于明杆阀，也可用于暗杆阀。可对阀门进行远控、集控和自动控制，广泛应用于电力、冶金、石油、化工、制药、污水处理、农业灌溉等行业。

本系列普通型产品性能符合GB/T24923-2010《普通型阀门电动装置技术条件》的规定；

本系列隔爆型产品性能符合GB3836.1-2010《爆炸性环境第1部分：通用要求》、GB3836.2-2010《爆炸环境第2部分：由隔爆外壳“d”保护的装置》及GB/T24922-2010《隔爆型阀门电动装置技术条件》的规定。

Z series actuators, are driving equipment for valves to achieve opening, closing, adjustment and control. This series of actuators have the characteristics of full-featured, reliable performance, advanced control system, small size, light weight, convenient use and maintenance.

Z series actuators are suitable for valves with linear movements, such as gate valves, globe valves, diaphragm valves, plunger valves, shut-off valves, water gates, etc., which can be used for bright stem valves and dark stem valves. The valve can be controlled remotely, collectively and automatically. It is widely used in electric power, metallurgy, petroleum, chemical, pharmaceutical, sewage treatment, agricultural irrigation and other industries.

The performance of this series of ordinary products meets the requirements of GB / T24923-2010 "Technical Conditions for Ordinary Valve Electric Devices";

The performance of this series of flameproof products conforms to GB3836.1-2010 "Explosive Environment Part 1: General Requirements", GB3836.2-2010 "Explosive Environment Part 2: Equipment Protected by Flameproof Enclosure" d "" and GB / T24922-2010 "Technical Conditions of Flameproof Valve Electric Device".

二：产品分类 / Product Categories

按控制方式分：普通型、智能开关型、智能调节型（Profibus现场总线、Modbus现场总线、Hart现场总线、FF现场总线、Device Net现场总线）；

按防护类型分：户外型和防爆型；

按连接方式分：转矩型和推力型；

Divided by control method: Divided by control method: ordinary type, intelligent switch type, intelligent adjustment type (Profibus fieldbus, Modbus Fieldbus, Hart fieldbus, FF fieldbus, Device Net fieldbus);

Divided by protection type: Outdoor and explosion-proof;

Divided by connection method: Torque type and thrust type;

三：主要技术指标 / Main Specifications

输入信号 Input signal	4mA~20mA; 无源触点 / Passive contact	
供电电源 Power supply	常规 Conventional	三相 / Three phase: AC380V (50Hz)
	特殊 Special	三相 / Three phase: AC660V、AC440V、AC415V (50Hz、60Hz)
		单相 / Simplex: AC220V、AC110V (50Hz、60Hz)
		直流 / Direct: DC12V、DC24V、DC48V
基本误差限 Basic error limit	≤1%	
防护等级 Protection class	IP65、IP68.....	
防爆型等级 Explosion-proof grade	ExdII BT4、ExdII CT4;	
环境温度 Ambient temperature	-30℃~+70℃ (可选 / Optional: -40℃~+100℃)	
环境湿度 Environment humidity	≤95% (25℃时)	
电机工作制: 标配长时电机, F级绝缘 Motor working system: Standard long-term motor, F-class insulation		

四：结构 / Structure

阀门电动装置有六个部分组成，电机，减速器，控制机构，手-电动切换机构，手轮部件及电气部分，其传动原理见图一。

The valve electric device is composed of six parts, the motor, reducer, control mechanism, hand-electric switching mechanism, hand wheel components and electrical parts. Its transmission principle is shown in Figure 1.

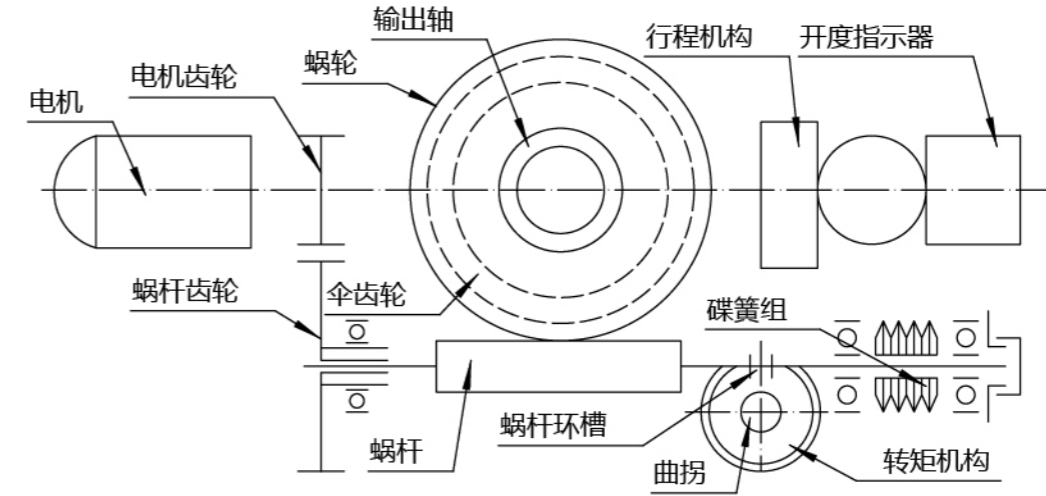

电机: Electric machinery	行程机构: Travel mechanism	蜗杆齿轮: Worm gear	蜗杆: worm
电机齿轮: Motor gear	开度指示器: Opening indicator	伞齿轮: Bevel gear	曲拐: Crank
碟簧组: Disc spring group	蜗杆环槽: Worm grooves	输出轴: Output shaft	蜗轮: Worm gear
转矩机构: Torque mechanism			

图一 传动原理图

Figure 1 Transmission schematic diagram

1.电动机：采用YDF2-W户外型三相异步电机，该电机为短时工作制，额定持续工作时间为10分钟。

2.减速器：由一对正齿轮和蜗轮付组成，电动机的动力经减速器传递给输出轴。

3.控制机构：由转矩控制机构，行程控制机构及可调式开度指示器组成，用以控制阀门的开启和关闭及阀位指示。

(1) 转矩控制机构（图二一）：由曲拐，挡块，凸轮分度盘，支板和微动开关组成，当输出轴受到一定阻转矩后，蜗杆除旋转外，还产生轴向位移，带动曲拐旋转，同时使挡块也产生一个角位移，从而迫近凸轮，使支板上抬。当输出轴上的转矩增大到预定值时，则支板上抬直至微动开关动作，切断电源，电机停转，以实现电动装置输出转矩的控制。

1. Motor: ydf2-w outdoor three-phase asynchronous motor is adopted, which is short-time working system and rated continuous working time is 10 minutes.

2. Reducer: it consists of a pair of spur gears and worm gear pairs. The power of the motor is transmitted to the output shaft through the reducer.

3. Control mechanism: it is composed of torque control mechanism, stroke control mechanism and adjustable opening indicator to control the opening and closing of valve and indication of valve position.

(1) Torque control mechanism (Fig. 2.1): it is composed of crank, stop, cam index plate, support plate and microswitch. When the output shaft is subject to certain resistance torque, the worm not only rotates, but also produces axial displacement, which drives the crank to rotate, at the same time, the stop also produces an angular displacement, so as to approach the cam and lift the support plate. When the torque on the output shaft increases to a predetermined value, the support plate is lifted until the microswitch acts, the power supply is cut off, and the motor stops running, so as to realize the control of the output torque of the electric device.

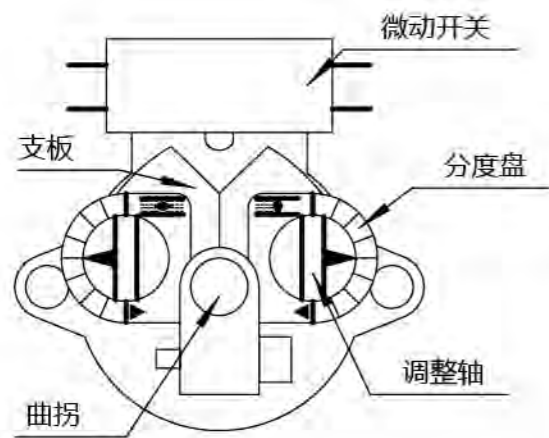

图二一 转矩控制机构
Figure 2.1 Torque control mechanism

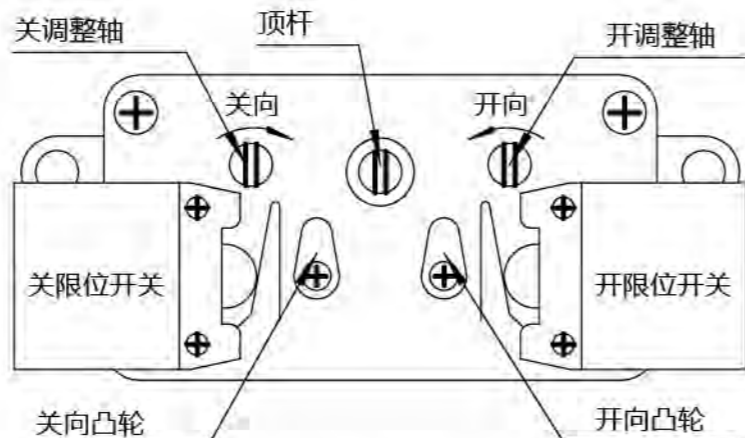

图二二 行程控制机构
Figure 2.2 Stroke control mechanism

微动开关: The micro switch	关限位开关: Close limit switch	调整轴: Adjusting shaft	顶杆: Ejector pin
支板: Supporting plate	开限位开关: Open limit switch	关调整轴: Off adjusting shaft	关向: Guan Dao
曲拐: Crank	关向凸轮: Closed cam	开调整轴: Adjusting shaft	开向: Open direction
分度盘: Dividing disc	开向凸轮: Open cam		

(2) 行程控制机构 (图二二): 由十进位齿轮组, 顶杆, 凸轮和微动开关组成, 简称计数器。其工作原理是由减速箱内的一主动小齿轮 ($Z=8$) 带动计数器工作。如果计数器按阀门开或关的位置已经调整好, 当计数器随输出轴转到预先调整好的位置 (圈数) 时, 则凸轮将被转动 90° , 压迫微动开关动作, 切断电源, 电机停转, 实现对电动装置行程 (圈数) 的控制。为了控制较多转圈数的阀门, 可调整凸轮转 180° 或 270° 再压迫微动开关动作。

(2) Stroke control mechanism (Fig. 2.2): composed of decimal gear set, ejector pin, cam and microswitch, referred to as counter. The working principle of the counter is driven by a driving pinion ($z = 8$) in the gearbox. If the counter has been adjusted according to the opening or closing position of the valve, when the counter is turned to the pre-adjusted position (number of turns) along with the output shaft, the cam will be turned 90° , pressing the microswitch action, cutting off the power supply, stopping the motor, and realizing the control of the electric device stroke (number of turns). In order to control the valve with more turns, adjust the cam to rotate 180° or 270° and press the microswitch again.

(3) 可调式开度指示器 (图三): 由减速齿轮组, 调节齿轮, 阀门开度表盘, 凸轮, 微动开关, 及电位器组成。在现场调试时, 可根据所配阀门开关的圈数, 将调节齿轮调整到所需的位置, 并与减速齿轮组啮合 (在立柱上有所需圈数的数字)。当阀门在开启或关闭的过程中, 开度盘经减速后转动, 指示阀门的开关量, 指示角度与阀门开关量同步, 供远传指示阀门位置用。

(3) Adjustable opening indicator (Figure 3): it is composed of reduction gear set, adjusting gear, valve opening dial, cam, microswitch and potentiometer. During on-site commissioning, the adjusting gear can be adjusted to the required position according to the number of turns of the valve switch, and it can mesh with the reduction gear set (there is a number of turns required on the column). In the process of opening or closing the valve, the opening plate rotates after slowing down to indicate the on-off value of the valve, and the indicating angle is synchronized with the valve on-off value for remote transmission to indicate the valve position.

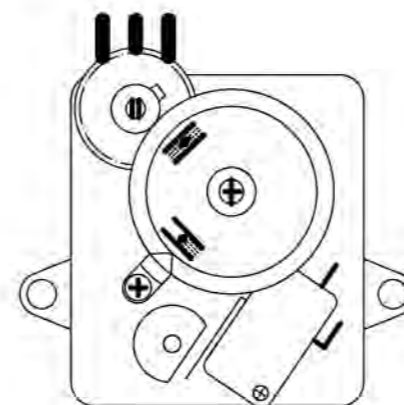

图三 开度指示器
Figure 3 Opening indicator

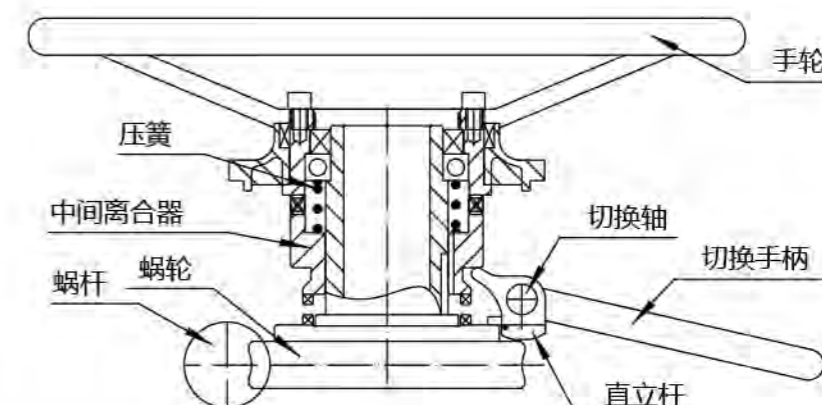

图四 手-电动切换机构
Figure 4 Hand electric switching mechanism

压簧: Pressure spring	中间离合器: Intermediate clutch	蜗轮: Worm gear
切换轴: Switching axis	切换手柄: Handover handle	蜗杆: worm
直立杆: Upright pole	手轮: handwheel	

手-电动切换机构 (图四): 为半自动切换, 电动转变为手动操作需扳动切换手柄, 由手动转变为自动时系自行进行 (不需要扳动切换手柄)。由电动变为手动时, 即人工扳动切换手柄, 使输出轴上的中间离合器向上移动, 压迫弹簧。当手柄推到一定位置时中间离合器脱离蜗轮与手动轴爪啮合, 则可使手轮上的作用力通过中间离合器传到输出轴上, 即成为手动状态。手动变为电动时自动切换, 当电机旋转带动蜗轮转动时直立杆立即倒下, 在压簧作用下中间离合器迅速向蜗轮方向移动, 与手动轴脱离, 与蜗轮啮合, 则成为电动状态。

Manual electric switching mechanism (Figure 4): it is semi-automatic switching, and the switching handle needs to be pulled for electric to manual operation, and it will be carried out by itself when it is changed from manual to automatic (no need to pull the switching handle). When changing from electric to manual, manually pull the switch handle to make the intermediate clutch on the output shaft move upward and press the spring. When the handle is pushed to a certain position and the clutch disengages from the worm gear and engages with the manual shaft claw, the force on the hand wheel can be transmitted to the output shaft through the intermediate clutch, that is to say, it becomes the manual state. When it is changed from manual to electric, it will switch automatically. When the motor rotates to drive the worm gear, the upright rod will fall down immediately. Under the action of the compression spring, the intermediate clutch will move towards the worm gear quickly, and it will be separated from the manual shaft and meshed with the worm gear, which will become the electric state.

五：外形尺寸 / Dimensions

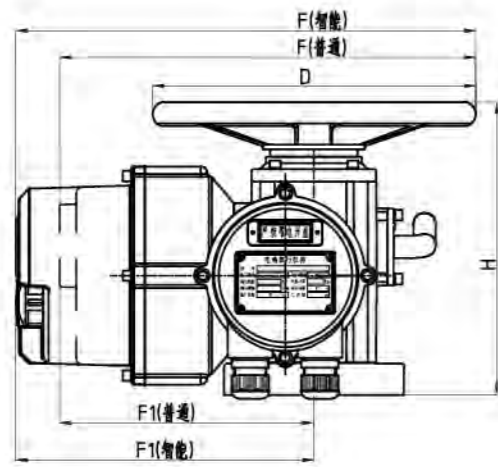

Z05/10/15

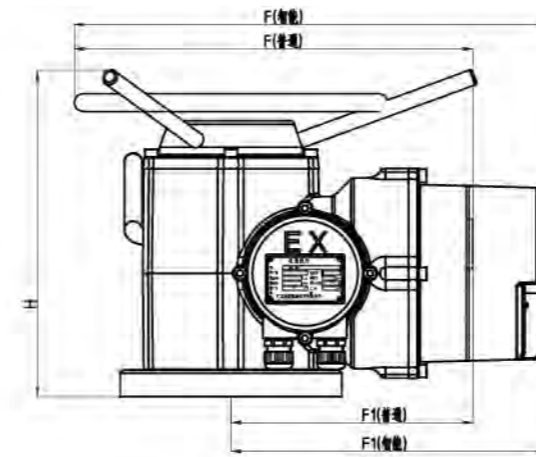
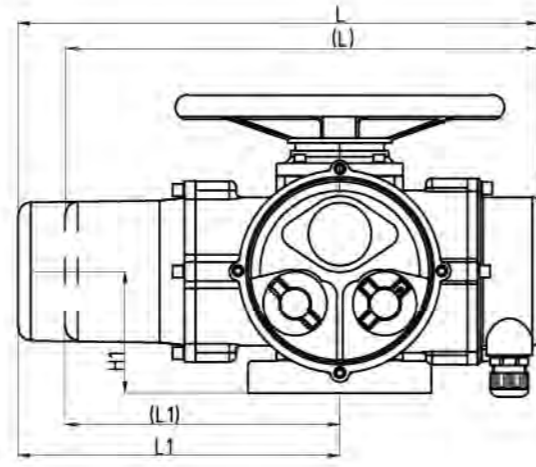

Z90/120

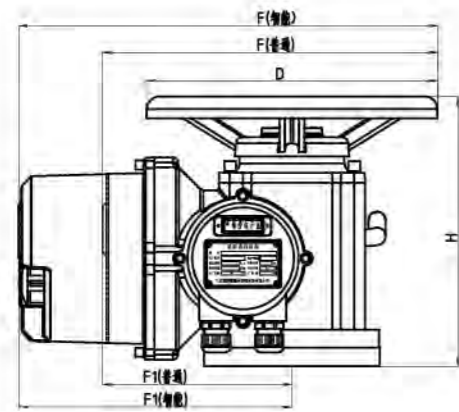
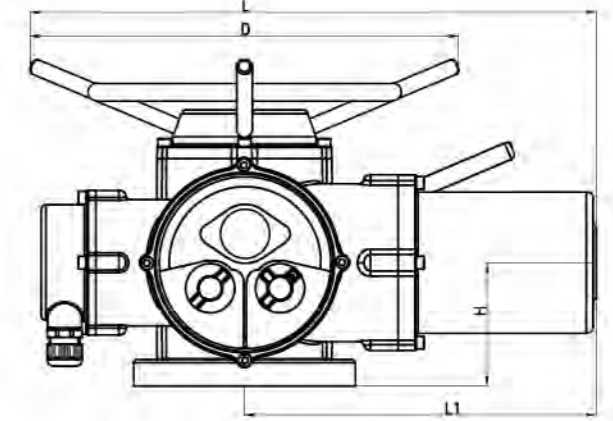

Z20/30

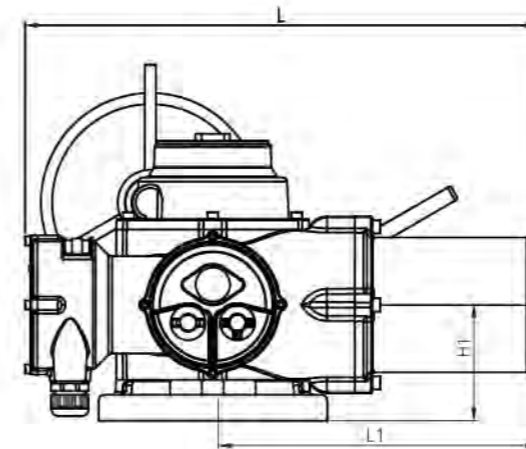
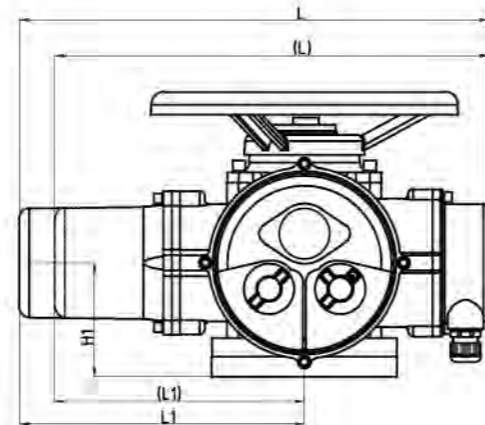

Z180/250

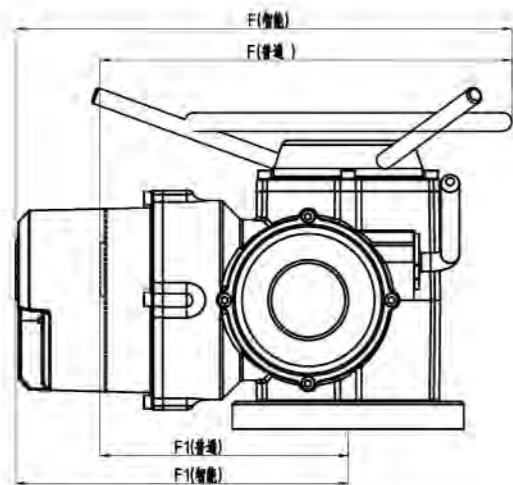
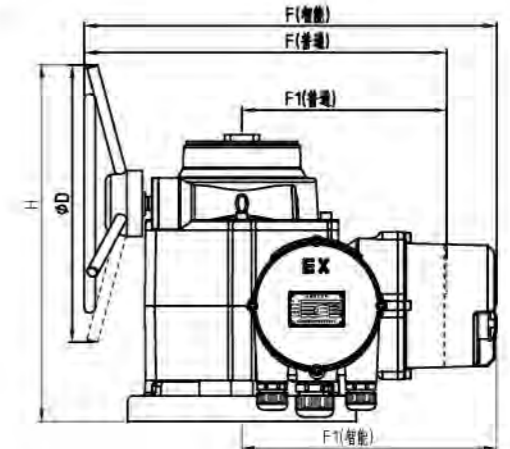

Z45/60

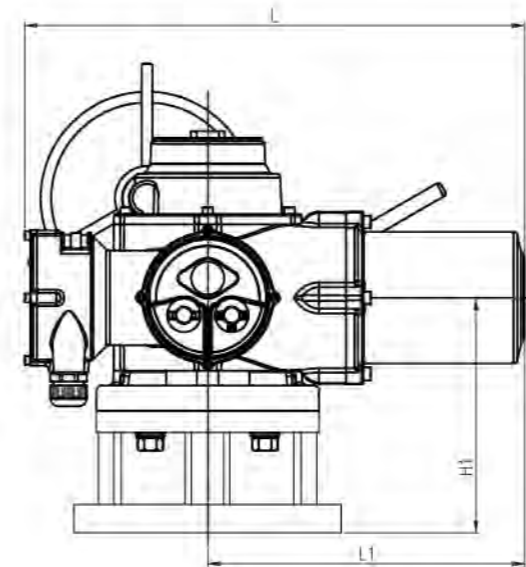
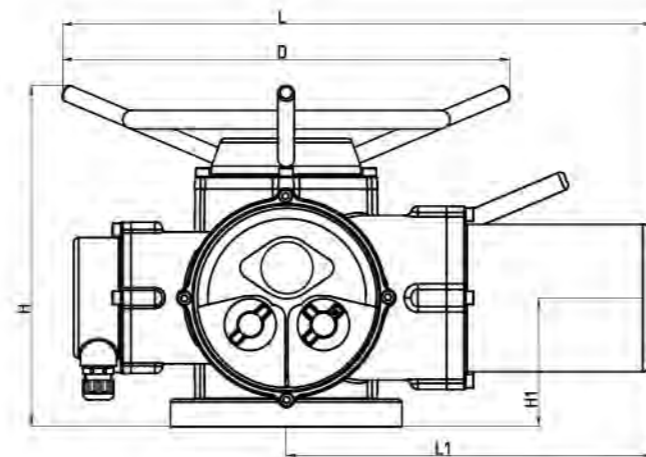

Z350/500/700/1000

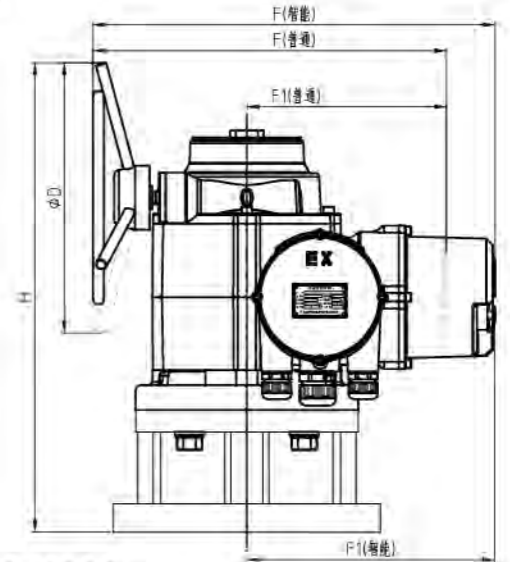

尺寸 Size 型号 Model	H	H1	F		F1		D	(L)	L	(L1)	L1
			普通 Ordinary	智能 Intelligence	普通 Ordinary	智能 Intelligence					
			Z05/10/15	236	96	334					
Z20/30	285	115	372	442	218	288	∅300	449	499	265	315
Z45/60	335	125	510	570	252	322	∅495	/	563	/	357
Z90/120	352	141	517	587	252	322	∅508	577	637	360	420
Z180/250	515	167	524	596	296	368	∅400	/	748	/	470
Z350/500	684	348	524	596	296	368	∅400	/	748	/	470
Z700/1000	747	411	524	596	296	368	∅400	/	748	/	470

六：法兰结构与连接尺寸 / Flange structure and connection dimensions

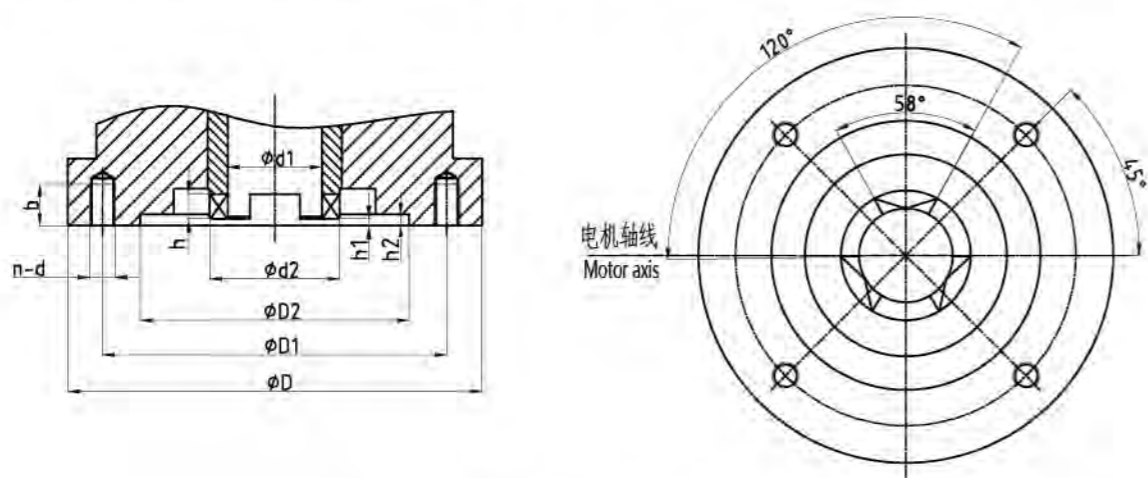

Z系列执行器接口尺寸（转矩型）
Z series actuator interface size(Torque type)

执行器型号 Actuator model	法兰型号 Flange model	执行器输出接口尺寸明细(转矩型 JB2920) Size details of actuator output interface(Torque type JB2920)										
		D	D1	D2	d1	d2	n-d	b	螺孔方向 Screw hole direction	h	h1	h2
Z05 Z10 Z15	2# 2#(I)	145 115	120 95	90 75	33 26	45 39	4-M10 4-M8	20	45°	8 6	2 2	5 5
Z20 Z30	3# 3#(I)	185 145	160 120	125 90	42 30	58 45	4-M12 4-M10	20	45°	10 8	2 2	5 5
Z45 Z60	4#	225	195	150	52	68	4-M16	27	45°	12	2	5
Z90 Z120	5# 5#(I)	275 230	235 195	180 150	62 50	78 72	4-M20 4-M16	30 27	45°	14 12	2 2	5 5
Z180 Z250	7#	330	285	220	72	98	4-M24	35	45°	16	3	6
Z350 Z500	8#	380	340	280	83	118	8-∅22	40	22.5°	20	3	7
Z700 Z1000	9#	430	380	300	93	128	8-∅26	42	22.5°	22	3.5	7

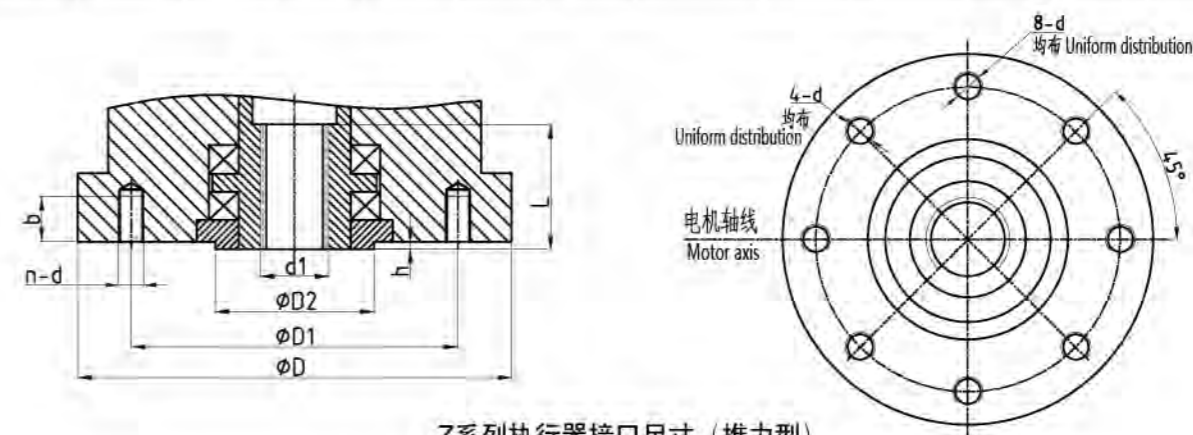

Z系列执行器接口尺寸（推力型）
Z series actuator interface size(Thrust type)

执行器型号 Actuator model	法兰型号 Flange model	执行器输出接口尺寸明细(推力型 GB12222) Size details of actuator output interface(Thrust type GB12222)									
		D	D1	D2	d1 梯形螺纹 (max) Trapezoid thread	n-d	b	螺孔方向 Screw hole direction	h	L	
Z05 Z10 Z15	F10	125	102	70	Tr28	4-M10	16	45°	3	40	
Z20 Z30	F14	175	140	100	Tr36	4-M16	25	45°	4	55	
Z45 Z60	F16	210	165	130	Tr44	4-M20	35	45°	5	70	
Z90 Z120	F25	300	254	200	Tr60	8-M16	30	45°	5	90	
Z180 Z250	F30	350	298	230	Tr70	8-M20	35	22.5°	5	110	
Z350 Z500	F35	415	356	260	Tr80	8-M30	45	22.5°	6	150	

七：型号及主要技术参数 / Model and main technical parameters

型号/规格 Model / Specification	输出转矩 Output torque (N.m)	输出转速 Output speed (r/min)	手动速比 Manual speed ratio (手轮/输出) (Handwheel / Output)	电机功率(kw) Motor power (380V)	额定电流(A) Rated current (380V)	参考重量 Reference weight (kg)
Z05	50	18/24	1:1	0.12/0.18	0.45/0.6	15.2
Z10	100	18/24	1:1	0.18/0.25	0.6/0.85	15.8
Z15	150	18/24	1:1	0.25/0.37	0.85/1.05	16.2
Z20	200	18/24	1:1	0.37/0.55	1.05/1.3	24.2
	200	36/48	1:1	0.55/0.75	1.3/1.7	24.2
Z30	300	18/24	1:1	0.55/0.75	1.3/1.7	25.8
	300	36/48	1:1	0.75/0.85	1.7/1.85	25.8
Z45	450	18/24	1:1	0.75/0.85	1.7/1.85	63
	450	36/48	1:1	1.1/1.5	2.5/3.2	63.2
Z60	600	18/24	1:1	1.1/1.5	2.5/3.2	65.2
	600	36/48	1:1	1.5/2.2	3.2/4.5	65.2
Z90	900	18/24	1:1	1.5/2.2	3.2/4.5	67.5
	900	36/48	1:1	2.2/3.0	4.5/6.3	68.5
Z120	1200	18/24	1:1	2.2/3.0	4.5/6.3	69.8
	1200	36/48	1:1	3.0/4.0	6.3/8.5	69.8
Z180	1800	18/24	1:21	4	8.5	120
Z250	2500	18/24	1:21	5	10.5	125
Z350/500	3500/5000	8	1:60	5	10.5	200
Z700/1000	7000/10000	4.5	1:107	5.5	11.2	260

八：电器控制部分 / Electrical control section

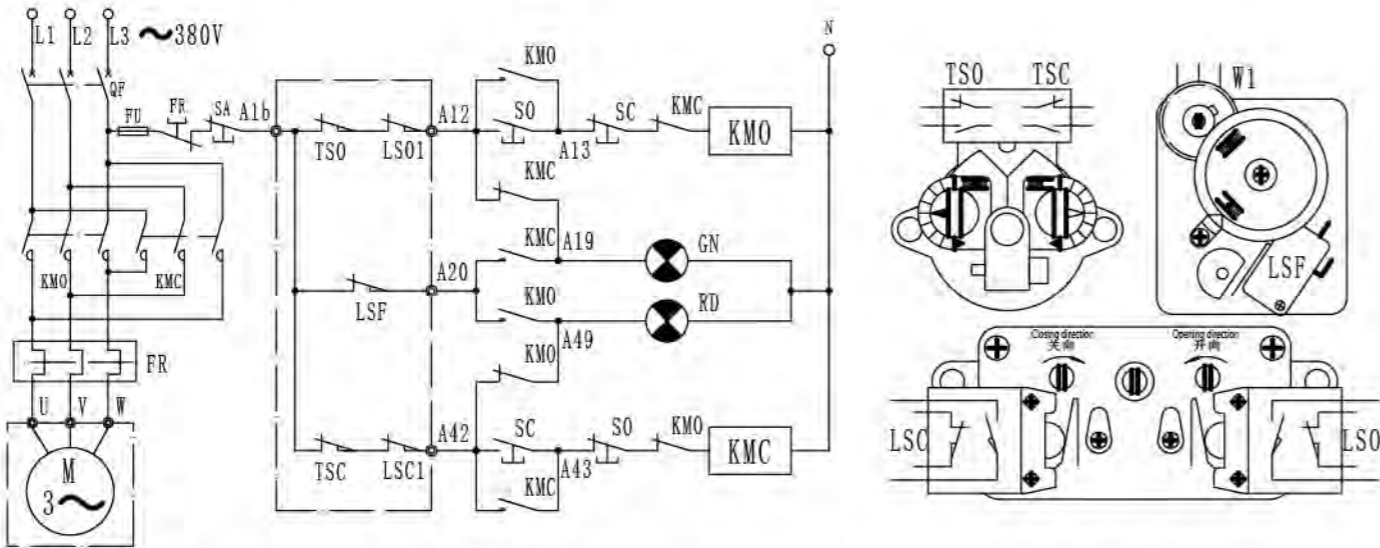

代号 Code name	名称 Name	型号 Model	数量 Number	备注 Remarks	代号 Code name	名称 Name	型号 Model	数量 Number	备注 Remarks
FR	热继电器 Thermal relay		1	用户自备 User self provided	LSF	闪光开关 Flash switch	V-157	1	
KMOKMC	交流接触器 AC contactor	GJ10	1	用户自备 User self provided	W1	电位器 potentiometer	WX14-12	1	
SASOSC	按钮 Button	LA11-11D	3	用户自备 User self provided	M	电机 Electric machinery	YDF2-W	1	
TSOTSC	转矩开关 Torque switch	DK3-2A	1		TH	热敏开关 Thermosensitive switch		1	特殊订货 Special order
LSOLSC	行程开关 Travel switch	HWK-22A	1		RT	空间加热器 Space heater		1	特殊订货 Special order



220V普通端子接线图
Wiring diagram of 220V common terminal

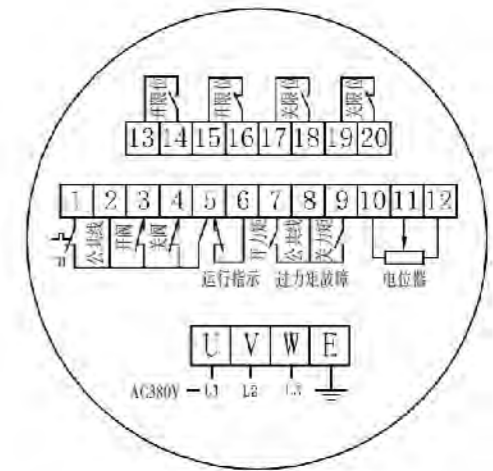

380V普通端子接线图
Wiring diagram of 380V common terminal



220V防爆端子接线图
Wiring diagram of 220V explosion-proof terminal

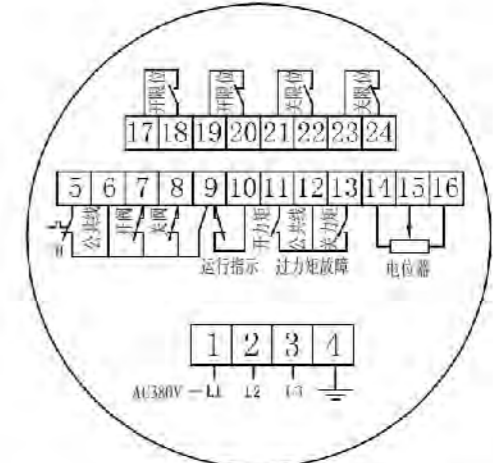

380V防爆端子接线图
Wiring diagram of 380V explosion-proof terminal

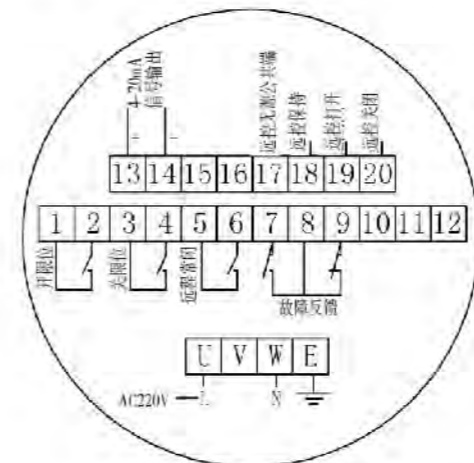

非侵入开关型220V端子接线图
Wiring diagram of non invading switch type 220V terminal

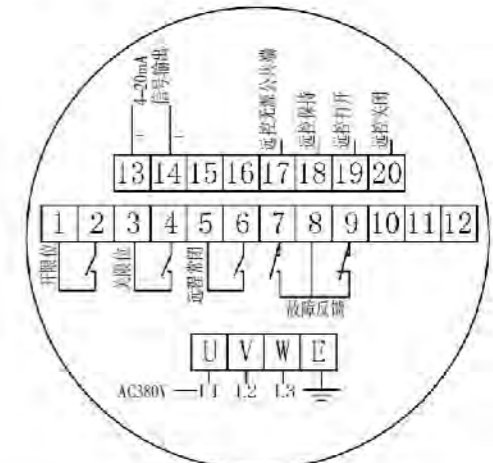

非侵入开关型380V端子接线图
Wiring diagram of non invading switch type 380V terminal

故障反馈 Fault feedback	开阀 Valve opening	关限位 Limit position	控制输入 Control input
信号输出 Signal output	关阀 Shut off valve	公共线 Common line	
远控打开 Remote control open	开力矩 Open torque	关力矩 Moment of closure	
远控常闭 Remote normal closure	开限位 Opening limit	电位器 Potentiometer	
运行指示 Operation instructions	过力矩故障 Over torque fault	远控关闭 Remote control shutdown	
远控保持 Remote control and maintenance	远控无源公共端 Remote control passive common terminal		

九：安装方式及使用注意事项 / Installation Methods and Precautions for Use

1. 本装置可垂直安装，水平安装，当电机不可向下，应便于接线，调试和手动操作。
2. 安装与阀门联接的牙嵌轴向间隙不小于1-2毫米。
3. 安装后初次使用必须按调试要求进行逐项调试，经常各部件正常后才能投入使用。
4. 本装置系采用电动装置用三相异步电机，额定持续工作时间为10分钟调试时应予注意。
5. 帮运时要小心轻放，保持干燥，防止接触腐蚀性物质，以免损坏电气元件和机械零件。

1. The device can be installed vertically and horizontally. When the motor cannot be installed downward, it shall be convenient for wiring, debugging and manual operation.
2. The axial clearance of the jaw connected with the valve shall not be less than 1-2mm.
3. The first use after installation must be debugged item by item according to the debugging requirements, and the components can only be put into use after they are normal.
4. The device adopts three-phase asynchronous motor for electric device, and attention shall be paid when the rated continuous working time is 10 minutes for commissioning.
5. Handle with care, keep dry and prevent contact with corrosive substances to avoid damage to electrical components and mechanical parts.

十：调整 / Adjustment

调整转矩，行程时，必须检查位置指示器上的电位器是否已脱开（把电位器轴上齿轮的紧定螺钉松开即可脱）开以防损坏。特别注意：新安装的电动装置首次电动时，必须检查电机相序，控制线路接线是否正确，以防电机失控。

When adjusting the torque and stroke, it is necessary to check whether the potentiometer on the position indicator is disengaged (loosen the set screw of the gear on the potentiometer shaft to be disengaged) to prevent damage. Special attention: when the newly installed electric device is powered for the first time, it is necessary to check the phase sequence of the motor and whether the wiring of the control circuit is correct, so as to prevent the motor from losing control.

1. 转矩控制机构调整：

- (1) 首先调整关转矩。
- (2) 从小转矩值开始，逐渐增大转矩值直到阀门关严为止。
- (3) 根据阀门工作特性调整开关方向转矩，一般开方向转矩要比关方向转矩大
- (4) 以上调整均在空载无介质压力等因素下调整，在有压力，温度时应注意其能否关严。如关不严则要适当增加转矩值以关得严打得开为准。

1. Adjustment of torque control mechanism:

- (1) First adjust the closing torque.
- (2) Starting from small torque value, gradually increase the torque value until the valve is closed tightly.
- (3) Adjust the torque of the switch direction according to the working characteristics of the valve. Generally, the torque in the open direction is larger than that in the close direction
- (4) All the above adjustments are made under no-load without medium pressure and other factors. When there is pressure and temperature, attention should be paid to whether it can be closed tightly. If it is not closed tightly, increase the torque value appropriately according to whether it is closed tightly or opened tightly.

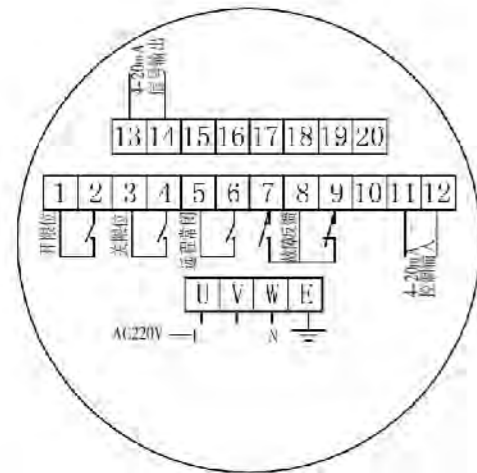

调节型220V端子接线图
Wiring diagram of regulated 220 V terminal

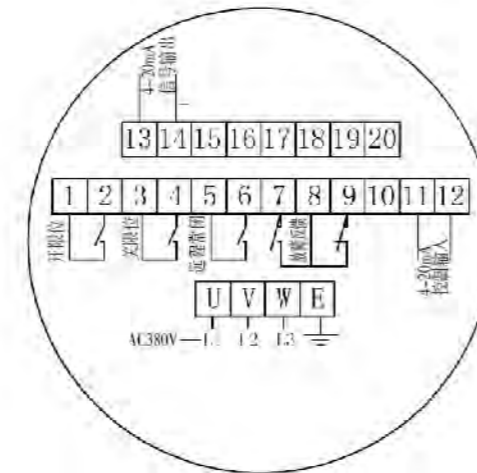

调节型380V端子接线图
Wiring diagram of regulated 380 V terminal

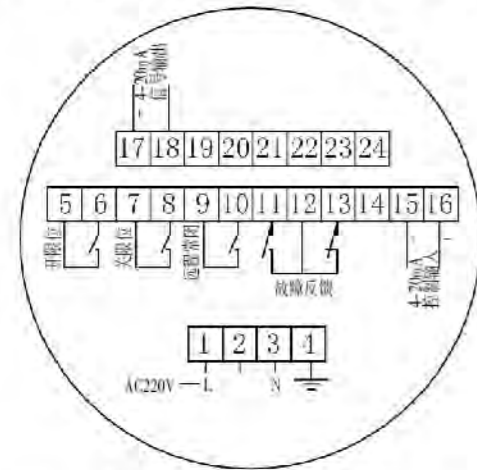

调节防爆型220V端子接线图
Wiring diagram of regulated explosion-proof 220V terminal

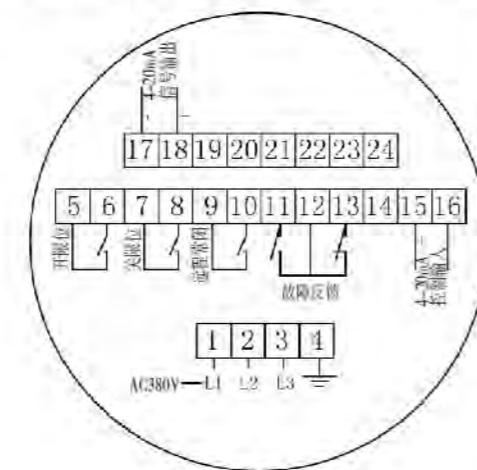

调节防爆型380V端子接线图
Wiring diagram of regulated explosion-proof 380V terminal

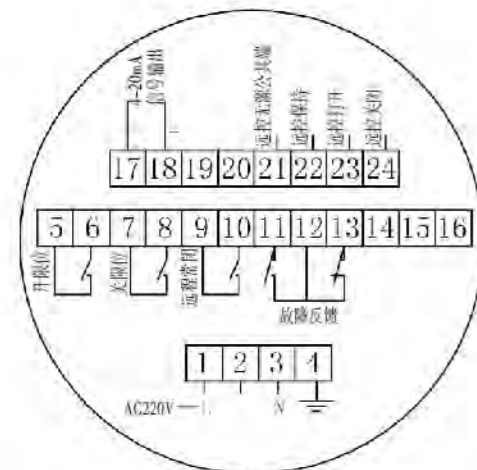

非侵防爆开关型220V端子接线图
Wiring diagram of non-invasive explosion-proof switch type 220V terminal

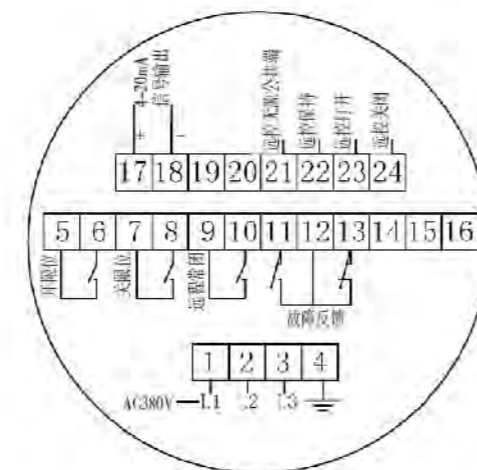

非侵防爆开关型380V端子接线图
Wiring diagram of non-invasive explosion-proof switch type 380V terminal

图七：电动装置端子接线图

Figure 7: terminal wiring diagram of electric device

2.行程控制机构调整：

(1) 用手动将阀门关严。

(2) 脱开行程控制机构，即用螺丝刀将行程控制机构中顶杆推进并转90°，使主动小齿轮与计数器个位齿轮组脱开。

(3) 用螺丝刀旋转“关”向调整轴，按箭头方向旋转直到凸轮压住弹簧压板使微动开关动作为止，则关向行程初步调好。

(4) 松开顶杆使主动齿轮与两边个位齿轮正确啮合，为保证其正确啮合，在松开顶杆后，必须用螺丝刀稍许左右转动调整轴。此时可以电动打开几圈，而后关闭，视关向行程是否符合要求，如不合要求，可以按上述程序重新调整。

(5) 开方向调整：在关方向调整好以后，用手将阀门开到所需位置（注意此时行程控制机构不能脱开，否则关向调整又被打乱），然后脱开行程控制机构，旋转“开”向调整轴，按箭头方向旋转直到凸轮压住弹簧压板使微动开关动作为止。再使行程机构与主动齿轮啮合，则开向行程调完。行程控制机构调完后，可反复操作几次。一般开阀门控制在90%左右。

2. Adjustment of travel control mechanism:

(1) Close the valve by hand.

(2) Disconnect the travel control mechanism, that is, use a screwdriver to push the ejector pin in the travel control mechanism and turn it 90° to separate the driving pinion from the counter gear set.

(3) Use a screwdriver to turn "close" to the adjusting shaft, and turn in the direction of the arrow until the cam presses the spring pressing plate to make the microswitch act, then the closing stroke is preliminarily adjusted.

(4) Loosen the ejector pin to make the driving gear and the individual gears on both sides mesh correctly. In order to ensure their correct engagement, after loosening the ejector pin, it is necessary to turn the adjusting shaft slightly left and right with a screwdriver. At this time, it can be electrically opened for several turns and then closed, depending on whether the closing stroke meets the requirements. If it does not meet the requirements, it can be readjusted according to the above procedures.

(5) Opening direction adjustment: after the closing direction is adjusted, open the valve to the required position by hand (note that the travel control mechanism cannot be disengaged at this time, otherwise the closing direction adjustment will be disturbed), then disconnect the travel control mechanism, rotate the "opening" direction adjustment shaft, and rotate in the direction of the arrow until the cam presses the spring pressing plate to make the microswitch act. Then make the stroke mechanism mesh with the driving gear, then the opening stroke is adjusted completely. After the stroke control mechanism is adjusted, it can be operated repeatedly for several times. Generally, the valve opening is controlled at about 90%.

3.可调式开度指示器的调整：

(1) 在调整好转矩，行程的基础上调整可调式开度指示和远传电位器。

(2) 将阀门关闭（手动或电动）

(3) 首先根据阀门的最大转圈数将齿轮组上的调节齿轮调到相应的位置上，再将表板的关符号推到指针处，转动电位器，使电位器在零位上，并使电位器轴上的齿轮与开度轴上的齿轮啮合，拧紧电位器轴上齿轮的紧定螺钉即可。

3. Adjustment of adjustable opening indicator:

(1) On the basis of adjusting torque and stroke, adjust adjustable opening indicator and remote potentiometer.

(2) Close the valve (manual or electric)

(3) First, adjust the adjusting gear on the gear set to the corresponding position according to the maximum turns of the valve, and then

Push the closing symbol of the meter board to the pointer, turn the potentiometer to make it at the zero position, and make it on the potentiometer shaft

The gear of is meshed with the gear on the opening shaft. Tighten the set screw of the gear on the potentiometer shaft.

十一：故障排除方法 / Troubleshooting methods

故障 fault	原因 Reason	排除方法 Elimination method
失控，转矩，行程控制机构均不起作用 Out of control, torque, stroke control mechanism do not work	1.线序接错 Wrong wiring sequence	1.调换线序 Exchange line order
	2.接触器线圈接错 Wrong connection of contactor coil	2.调换接线 Switch wiring
	3.接触器吸铁不释放 Contactor iron absorption does not release	3.清洁或调换接触器 Clean or replace the contactor
行程控制机构失灵 Travel control mechanism failure	1.微动开关损坏 Microswitch damaged	1.更换 Replace
	2.微动开关位置移动 Microswitch position move	2.检查拧紧 Check tightening
转矩控制机构失灵 Torque control mechanism failure	1.微动开关损坏 Microswitch damaged	1.更换 Replace
	2.碟簧特性破坏 Failure of disc spring characteristics	2.更换 Replace
开度指示控制机构失灵 Failure of opening indication control mechanism	1.电位器损坏 Potentiometer damaged	1.更换 Replace
	2.啮合齿轮松动 Loose engagement gear	2.拧紧紧定螺丝 Tighten the set screw
	3.导线接错不良 Wrong wire connection	3.跟换新线 Follow the new line
电机运转不正常,有连续嗡嗡声 The motor runs abnormally, with continuous buzzing	二相运行 Two phase operation	检查动力回路接通三相 Check that the power circuit is connected to three phases

十二：用行程与转矩控制阀门终端位置的选择（供参考）

Use stroke and torque to control the selection of valve terminal position (for reference)

阀门种类 Valve type	控制方法 Control method	
	关向 Direction of closing	开向 Direction of opening
自密封（闸阀） Self sealing (gate valve)	行程 Trip	行程 Trip
强制密封（闸阀） Forced seal (gate valve)	转矩 torque	行程 Trip
截止阀 Globe valve	转矩 torque	行程 Trip
密封蝶阀 Sealed butterfly valve	转矩 torque	行程 Trip
非密封蝶阀 Unsealed butterfly valve	行程 Trip	行程 Trip
球阀 Globe valve	行程 Trip	行程 Trip

十三：检修备品 / Maintenance spare parts

本装置一般正常情况下允许工作10000次，如因操作检修不当而损坏零件，本公司可提供如下备品。

The device is generally allowed to work 10000 times under normal conditions. If parts are damaged due to improper operation and maintenance, the company can provide the following spare parts.

- | | |
|-----------------|--|
| 1.微动开关 | 1. Microswitch |
| 2.各种“O”型耐油橡胶密封圈 | 2. Various "O" type oil resistant rubber sealing rings |
| 3.各种骨架油封 | 3. Various framework oil seals |
| 4.弹簧 | 4. spring |
| 5.蝶形弹簧 | 5. Butterfly spring |
| 6.行程控制机构（计数器） | 6. Travel control mechanism (counter) |
| 7.可调式开度指示器 | 7. Adjustable opening indicator |

十四：非侵型电控组件调试说明

非侵型是我公司在数字型产品基础上开发的。其可接收DCS系统中PLC等控制器发出的开关量信号（无源干触点、有源24V、有源220V，点动保持可切换）或模拟量信号（DC4~20mA、0~10V等），可直接驱动，也可通过接触器或固态继电器驱动电动执行器动作。输出DC4~20mA反馈电流和四个继电器触点（开位、关位、远控、故障报警）。该组件集成了伺服控制单元、液晶显示单元、旋钮操作等单元。本产品操作简单，保护功能完善，是您重新定义高品质和简易智能型的最佳选择。

Non intrusive products are developed by our company on the basis of digital products. It can receive the on-off signal (passive dry contact, active 24V, active 220V, inching and holding can be switched) or analog signal (dc4-20ma, 0-10V, etc.) sent by PLC and other controllers in DCS system, and it can be directly driven, or it can also drive the electric actuator through contactor or solid-state relay. Output DC4 ~ 20mA feedback current and four relay contacts (open position, close position, remote control, fault alarm). The module integrates servo control unit, liquid crystal display unit, knob operation unit, etc. With simple operation and perfect protection function, this product is the best choice for you to redefine high quality and simple intelligent type.

1. 旋钮操作说明

红色旋钮为方式钮，可在现场/停止/远方之间切换；或在设定状态实现菜单的保存（从停位旋到现场）和退出（从停位旋到远方）。黑色旋钮为操作钮，可在现场模式进行打开或关闭操作，或在设定状态进行加减设置。现场旋钮操作时，短时间作用为现场点动模式，当操作钮有效作用时间超过3秒钟后报警区显示“bc”为自动进入现场保持模式，反向旋操作钮或将方式钮旋到停止，即停止动作。

1. Operating instructions for knobs

The red knob is the mode button, which can be switched between site / stop / remote; or the menu can be saved (from stop to site) and exited (from stop to remote) in the set state. The black knob is the operation knob, which can be opened or closed in the field mode, or set up plus and minus in the set state. When the field knob is operated, the short-term action is the field inching mode. When the effective action time of the operation knob exceeds 3 seconds, the alarm area displays "BC" as the automatic entry into the field holding mode. Turn the operation knob reversely or turn the mode knob to the stop, that is to say, stop the operation.

2. 遥控器操作说明（遥控器为选配件，需要时请在订货时特殊说明）

Remote control operation instructions (remote control is an option, please give special instructions when ordering if necessary)

- | | | | |
|-------|----------|-------|----------|
| Up | --上移/开标定 | Down | --下移/关标定 |
| Enter | --确认/保存 | Stop | --停止/退出 |
| Open | --值加/现场开 | Close | --值减/现场关 |

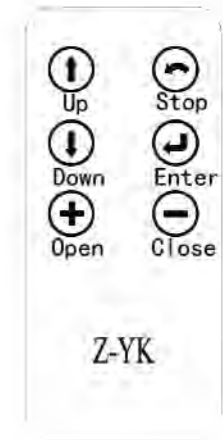

在现场方式时，按“Open”键执行保持方式开阀，按“Close”键执行保持方式关阀，按“Stop”键停动。现场方式，连按三次“Up”键进入开位标定状态，“Open”、“Close”、“Stop”键可控制电动执行器开、关、停，“Enter”键用于保存行程，“Stop”键用于返回。

现场方式，连按三次“Down”键进入关位标定状态，其它操作同上。

现场方式，连按三次“Enter”键进入高级设置菜单，菜单内“Up”、“Down”键用于菜单上移、下移，“Open”、“Close”用于参数值改变，“Enter”键用于进入菜单和保存参数，“Stop”键用于返回上级和退出菜单。

In the field mode, press the "open" key to open the valve in the holding mode, Press "close" to close the valve in holding mode, and press "stop" to stop.

In the field mode, press the "up" key three times to enter the open position calibration state, the "open", "close" and "stop" keys can control the opening, closing and stopping of the electric actuator, the "enter" key is used to save the stroke, and the "stop" key is used to return.

In the field mode, press the "down" key three times to enter the off position calibration state, and other operations are the same as above.

In the field mode, press the "enter" key three times to enter the advanced setting menu. The "up" and "down" keys in the menu are used to move up and down the menu. The "open" and "close" keys are used to change the parameter value. The "enter" key is used to enter the menu and save the parameter. The "stop" key is used to return to the superior and exit the menu.

3. 信号查询（显示屏左下角为信号查询区）

3.1. 远控信号查询

方式钮旋到远方，在显示屏的左下角显示接收到的远控信号。开关型：OP代表有远方打开；CL代表有远方关闭；bc代表有远方保持（多状态并存时交替显示）。调节型：显示收到控制电流值或电压值。

3.2. 阀位信号查询

方式钮旋到现场，显示屏左下角显示阀位信号。阀位采集为电位器时显示阻值的百分比（d01~d99）；阀位采集为12位编码器时显示编码器的百分比（b00~b99）；阀位采集为18位编码器时显示编码器的千分比（000~999）。

3. Signal query (the lower left corner of the display is the signal query area)

3.1. Remote control signal query

Turn the mode button to the remote position, and the received remote control signal will be displayed in the lower left corner of the display screen. Switch type: OP stands for remote opening; CL stands for remote closing; BC stands for remote holding (alternate display when multiple states coexist). Regulating type: display the received control current value or voltage value.

3.2. Valve position signal query

Turn the mode button to the site, and the lower left corner of the display shows the valve position signal. When the valve position acquisition is potentiometer, it shows the percentage of resistance value (d01-d99); when the valve position acquisition is 12 bit encoder, it shows the percentage of encoder (b00-b99); when the valve position acquisition is 18 bit encoder, it shows the thousandth ratio of encoder (000-999).

4. 行程标定

4.1 关位标定

停止位置旋操作钮至关闭约3秒钟，等到闪烁显示字母L时松开操作钮并将方式钮旋到现场,此时L不再闪烁表示进入关位标定状态。可通过操作钮执行电动开或电动关动作，调整到关位后将方式钮旋到停止再旋回现场,此时字母L闪两次，输出反馈电流为4mA同时驱动关位继电器闭合并显示0%表示关位标定完成。若方式钮由停止旋至远方则直接退出行程标定。

4. Stroke calibration

4.1 off position calibration

When the stop position is turned to the off position for about 3 seconds, release the operation button and turn the mode button to the site when the display letter L flashes. At this time, when L no longer flashes, it means entering the off position calibration state. The electric opening or closing action can be performed through the operation button. After adjusting to the closing position, turn the mode button to the stop and then turn it back to the site. At this time, the letter L flashes twice, and the output feedback current is 4mA. At the same time, drive the closing relay to close and display 0% to indicate that the closing calibration is completed. If the mode button is turned from stop to remote position, it will exit the stroke calibration directly.

4.2 开位标定

停止位置旋操作钮至打开约3秒钟，等到闪烁显示字母H时松开操作钮并将方式钮旋到现场,此时H不再闪烁表示进入开位标定状态。可通过操作钮执行电动开或电动关动作，调整到开位后将方式钮旋到停止再旋回现场,此时字母H闪两次，输出反馈电流为20mA同时驱动开位继电器闭合并显示100%表示开位标定完成。若方式钮由停止旋至远方则直接退出行程标定。

注：保存行程时，出现Fu或Fn报警时，请重新调整编码器的旋转区间，并重标行程；

4.2 open position calibration

When the stop position is turned to the open position for about 3 seconds, release the operation button and turn the mode button to the site when the flashing letter H is displayed. At this time, h will no longer flash to indicate entering the open position calibration state. The electric opening or closing action can be performed through the operation button. After adjusting to the opening position, turn the mode button to the stop and then turn it back to the site. At this time, the letter H flashes twice, and the output feedback current is 20mA. At the same time, drive the opening relay to close and display 100% to indicate that the opening calibration is completed. If the mode button is turned from stop to remote position, it will exit the stroke calibration directly.

Note: when saving the stroke, in case of Fu or FN alarm, please readjust the rotation range of encoder and remark the stroke;

5. 输出电流微调

5.1 4mA输出电流微调

停止位置旋操作钮至关闭约10秒钟，等到闪烁显示字母LF时松开操作钮并将方式钮旋到现场再旋回停止,即进入4mA输出电流微调状态。此时可通过操作钮调整输出电流的大小，调整输出电流达到 4mA后将方式钮旋到现场，此时LF闪烁两次表示4mA输出电流微调完成。若方式钮由停止旋至远方则直接退出输出电流微调状态。

5. Output current fine adjustment

5.1 4mA output current fine adjustment

Turn the operation button to the stop position for about 10 seconds, release the operation button when the flashing display letter LF is displayed, turn the mode button to the site, and then turn it back to stop, that is, enter the 4mA output current fine-tuning state. At this time, the output current can be adjusted through the operation button. When the output current reaches 4mA, turn the mode button to the site. At this time, LF flashes twice to indicate that the output current of 4mA is fine-tuning. If the mode button is turned from stop to remote, it will directly exit from the output current fine-tuning state.

5.2 20mA输出电流微调

停止位置旋操作钮至打开约10秒钟，等到闪烁显示字母HF时松开操作钮并将方式钮旋到现场再旋回停止,即进入20mA输出电流微调状态。此时可通过操作钮调整输出电流的大小，调整输出电流达到20mA后将方式钮旋到现场，此时HF闪烁两次表示20mA输出电流微调完成。若方式钮由停止旋至远方则直接退出输出电流微调状态。

6. 死区设置（此功能只适用于调节型）

死区为自调节，无需设置，且精度更高无震荡。

5.2 20 mA output current fine adjustment

Turn the operation button to the stop position for about 10 seconds, release the operation button when the flashing display letter HF is displayed, turn the mode button to the site, and then turn it back to stop, that is, enter the 20mA output current fine-tuning state. At this time, the output current can be adjusted through the operation button. After the output current reaches 20mA, turn the mode button to the site. At this time, HF flickers twice to indicate that the output current of 20mA is fine adjusted. If the mode button is turned from stop to remote, it will directly exit from the output current fine-tuning state.

6. Deadband setting (this function is only applicable to the adjustable type)

The deadband is self-adjusting, no need to set, and the accuracy is higher without vibration.

7. 高级设置

停止位置，旋操作钮至打开约18秒钟，等到闪烁显示字母CF时松开操作钮并将方式钮旋到现场再旋回停止，即进入高级设置菜单。

遥控操作时，现场方式连按三次“Enter”键即可进入高级设置菜单。

注：各级菜单内，若方式钮由停止旋至远方（或按遥控器“Stop”键）则返回上级或退出菜单。

7. Advanced settings

In the stop position, turn the operation button to the open position for about 18 seconds. When the letter CF is flashing, release the operation button, turn the mode button to the site, and then turn the button back to the stop position to enter the advanced setting menu.

During remote control operation, press "enter" three times in field mode to enter advanced setting menu.

Note: in all levels of menus, if the mode button is turned from stop to remote (or press the "stop" key of the remote control), return to the upper level or exit the menu.

7.1 CF---关闭方向（默认值---C，顺时针）

菜单项移至“CF”然后将方式钮旋到现场再旋回停止（或按遥控器“Enter”键），即进入关闭方向设置，此时显示屏左下角显示参数值C---顺时针，A---逆时针，可通过操作钮调整参数值（或按遥控器“Open”、“Close”键），调整好后将方式钮旋到现场再旋回停止（或按遥控器“Enter”键），此时CF闪烁两次表示关闭方向设置完成并退回上级菜单。

7.1 CF --- closing direction (default value --- C, clockwise)

Move the menu item to "CF" and turn the mode button to the site and then turn it back to stop (or press the "enter" key of the remote control), that is, enter the setting of the closing direction. At this time, the parameter value C --- clockwise, a --- counterclockwise is displayed in the lower left corner of the display screen. Adjust the parameter value (or press the "open" and "close" keys of the remote control). After adjustment, turn the mode button to the site and then turn it back to stop (or press the "enter" key of the remote control) Press the "enter" key of the remote control, when CF flashes twice, it means that the closing direction setting is completed and the upper menu is returned.

7.2 LS---控制低信

菜单项移至“LS”然后将方式钮旋到现场再旋回停止（或按遥控器“Enter”键），即进入控制低信设置，此时显示屏左下角显示收到控制电流值或电压值，当控制信号改变时参数值同步改变，调整好后将方式钮旋到现场再旋回停止（或按遥控器“Enter”键），此时LS闪烁两次表示控制低信设置完成并退回上级菜单。

7.2 LS --- control low signal

Move the menu item to "LS" and turn the mode button to the site and then turn it back to stop (or press the "enter" key of the remote control), that is, enter the control low signal setting. At this time, the lower left corner of the display shows the received control current value or voltage value. When the control signal changes, the parameter value changes synchronously. After adjustment, turn the mode button to the site and then turn it back to stop (or press the "enter" key of the remote control). At this time, LS Flashing twice indicates that the control low signal setting is completed and returned to the upper menu.

7.3 HS---控制高信

菜单项移至“HS”然后将方式钮旋到现场再旋回停止（或按遥控器“Enter”键），即进入控制低信设置，此时显示屏左下角显示收到控制电流值或电压值，当控制信号改变时参数值同步改变，调整好后将方式钮旋到现场再旋回停止（或按遥控器“Enter”键），此时HS闪烁两次表示控制低信设置完成并退回上级菜单。

7.3 HS- control high signal

Move the menu item to "HS" and turn the mode button to the site and then turn it back to stop (or press the "enter" key of the remote control), that is, enter the control low signal setting. At this time, the lower left corner of the display shows the received control current value or voltage value. When the control signal changes, the parameter value changes synchronously. After adjustment, turn the mode button to the site and then turn it back to stop (or press the "enter" key of the remote control). At this time, HS Flashing twice indicates that the control low signal setting is completed and returned to the upper menu.

7.4 CA---死区设置（默认值-A，死区自适应）

菜单项移至“CA”然后将方式钮旋到现场再旋回停止（或按遥控器“Enter”键），即进入死区设置，此时显示屏左下角显示参数值A---死区自适应、03~99---死区设定0.3%~9.9%，可通过操作钮调整参数值（或按遥控器“Open”、“Close”键），调整好后将方式钮旋到现场再旋回停止（或按遥控器“Enter”键），此时CA闪烁两次表示死区设置完成并退回上级菜单。

7.4 CA --- deadband setting (default value - A, deadband adaptive)

Move the menu item to "CA" and turn the mode button to the site and then turn it back to stop (or press the "enter" key of the remote control), that is, enter the dead zone setting. At this time, the lower left corner of the display shows the parameter value a --- dead Zone adaptive, 03 ~ 99 --- dead zone setting 0.3% ~ 9.9%. You can adjust the parameter value through the operation button (or press the "open" and "close" keys of the remote control). After adjustment, turn the mode button to the site Then turn the cycle to stop (or press the "enter" key of the remote control), when the CA flashes twice, it indicates that the dead zone setting is completed and returns to the upper menu.

7.5 CS---丢信动作（默认值-丢信保位，调节型时此设置有效）

菜单项移至“CS”然后将方式钮旋到现场再旋回停止（或按遥控器“Enter”键），即进入丢信动作设置，此时显示屏左下角显示参数值OP---丢信开、CL---丢信关、SP---丢信保位，可通过操作钮调整参数值（或按遥控器“Open”、“Close”键），调整好后将方式钮旋到现场再旋回停止（或按遥控器“Enter”键），此时CS闪烁两次表示丢信动作设置完成并退回上级菜单。

7.5 CS --- loss of signal action (default value - loss of signal protection position, this setting is effective when it is adjustable)

Move the menu item to "CS" and then turn the mode button to the site and then turn it back to stop (or press the "enter" key of the remote control), that is, enter the setting of the loss of information action. At this time, the lower left corner of the display shows the parameter values OP --- loss of information on, CL --- loss of information off, SP --- loss of information protection. You can adjust the parameter values (or press the "open" and "close" keys of the remote control) through the operation button. After the adjustment, turn the mode button to the site Turn it back to stop (or press the "enter" key of the remote control), at this time, CS flashes twice to indicate that the setting of the lost signal action is completed and returns to the upper menu.

7.6 CH---两线控制（默认值-常规控制，开关型时此设置有效）

菜单项移至“CH”然后将方式钮旋到现场再旋回停止（或按遥控器“Enter”键），即进入两线控制设置，此时显示屏左下角显示参数值OP---有信开无信关、CL---有信关无信开、SP---常规控制，可通过操作钮调整参数值（或按遥控器“Open”、“Close”键），调整好后将方式钮旋到现场再旋回停止（或按遥控器“Enter”键），此时CH闪烁两次表示丢信动作设置完成并退回上级菜单。

7.6 ch --- two wire control (default - general control, this setting is effective when the switch type is used)

Move the menu item to "ch" and then turn the mode button to the site and then turn it back to stop (or press the "enter" key of the remote control), that is, enter the two-wire control setting. At this time, the lower left corner of the display shows the parameter values OP --- with or without signal on, CL --- with or without signal on, SP --- general control. You can adjust the parameter values through the operation button (or press the "open" and "close" keys of the remote control). After the adjustment is completed, you can adjust the parameter values Turn the button to the site and then turn it back to stop (or press the "enter" key of the remote control). At this time, ch flashes twice to indicate that the setting of the lost signal action is completed and returns to the upper menu.

7.7 CU---正反作用（默认值---正作用，调节型时此设置有效）

菜单项移至“CU”然后将方式钮旋到现场再旋回停止（或按遥控器“Enter”键），即进入正反作用设置，此时显示屏左下角显示参数值P---正作用，n---反作用，可通过操作钮调整参数值（或按遥控器“Open”、“Close”键），调整好后将方式钮旋到现场再旋回停止（或按遥控器“Enter”键），此时CU闪烁两次表示关闭方向设置完成并退回上级菜单。

7.7 Cu - positive and negative action (default value - positive action, this setting is effective when the adjustment type is used)

Move the menu item to "Cu" and turn the mode button to the site and then turn it back to stop (or press the "enter" key of the remote control), that is, enter the positive and negative action setting. At this time, the lower left corner of the display shows the parameter value p --- positive action, n --- negative action. You can adjust the parameter value (or press the "open" and "close" keys of the remote control) through the operation button. After the adjustment, turn the mode button to the site and then turn it back to stop (or Press the "enter" key of the remote control), and the Cu flashes twice, indicating that the closing direction setting is completed and the upper menu is returned.

7.8 Cd---堵转时间（默认值---20）

菜单项移至“Cd”然后将方式钮旋到现场再旋回停止（或按遥控器“Enter”键），即进入堵转时间设置，此时显示屏左下角显示参数值03-99，可通过操作钮调整参数值（或按遥控器“Open”、“Close”键），调整好后将方式钮旋到现场再旋回停止（或按遥控器“Enter”键），此时Cd闪烁两次表示关闭方向设置完成并退回上级菜单。

7.8 CD --- locked rotor time (default value --- 20)

Move the menu item to "CD" and turn the mode button to the site and then turn it back to stop (or press the "enter" key of the remote control), that is, enter the locked rotor time setting. At this time, the parameter value 03-99 is displayed in the lower left corner of the display screen. You can adjust the parameter value (or press the "open" and "close" keys of the remote control) through the operation button. After the adjustment, turn the mode button to the site and then turn it back to stop (or press the "enter" key of the remote control) Key), CD flashes twice at this time, indicating that the closing direction setting is completed and returns to the upper menu.

7.9 CE---恢复出厂值

若在菜单设置过程中将各参数设乱了，可用此项来恢复除行程的“开位”、“关位”和“关闭方向”参数外的出厂设置值。具体做法为：菜单项移至“CE”然后将方式钮旋到现场再旋回停止（或按遥控器“Enter”键），即进入恢复出厂值设置，此时显示屏左下角显示参数值，no---不恢复，yes---恢复，可通过操作钮调整参数值（或按遥控器“Open”、“Close”键），然后将方式钮旋到现场再旋回停止（或按遥控器“Enter”键），此时CE闪烁两次表示恢复出厂值完成并退回上级菜单。

7.9 CE --- restore factory value

If the parameters are set disorderly in the menu setting process, this item can be used to restore the factory settings except for the "on", "off" and "close direction" parameters of the stroke.

The specific method is as follows: move the menu item to "CE" and turn the mode button to the site and then turn it back to the stop (or press the "enter" key of the remote control), that is, enter the factory value restoration setting. At this time, the parameter value is displayed in the lower left corner of the display screen, no --- no restoration, yes --- restoration. Adjust the parameter value (or press the "open" and "close" keys of the remote control), and then turn the mode button to the site and then Cycle to stop (or press the "enter" key of the remote control), when CE flashes twice, it means that the factory value is restored and returned to the upper menu.

8.1 Id---通道地址 (默认值---003)

通道地址是指总线控制时所能被主控系统(主站)和自身识别的身份代码

菜单项移至“Id”然后将方式钮旋到现场再旋回停止(或按遥控器“Enter”键),即进入通道地址设置,此时显示屏左下角显示参数值000-247,可通过操作钮或调整参数值(或按遥控器“Open”、“Close”键),调整好后将方式钮旋到现场再旋回停止(或按遥控器“Enter”键),此时Id闪烁两次表示通道地址设置完成并退回上级菜单。

8.1 ID --- channel address (default address --- 003)

Channel address refers to the identification code that can be identified by the master control system (master station) and itself during bus control

Move the menu item to "Id" and then turn the mode button to the site and then turn it back to stop (or press the "enter" key of the remote control), that is, enter the channel address setting. At this time, the parameter value 000-247 is displayed in the lower left corner of the display screen. You can turn the mode button to the site and then turn it back to stop (or press the "enter" key of the remote control) after adjustment by operating the button or adjusting the parameter value (or press the "open" and "close" keys of the remote control) "Key), and the ID flashes twice to indicate that the channel address setting is completed and returns to the upper menu.

8.2 bd---波特率 (默认值---096)

波特率是指总线控制回路上每秒中传送的数据位数,通常用KB/S(千位/秒)表示。

菜单项移至“bd”然后将方式钮旋到现场再旋回停止(或按遥控器“Enter”键),即进入波特率设置,此时显示屏左下角显示参数值003-384(003-0.3KB/S、006-0.3KB/S、012-1.2KB/S、024-2.4KB/S、048-4.8KB/S、096-9.6KB/S、192-19.2KB/S、384-38.4KB/S),可通过操作钮或调整参数值(或按遥控器“Open”、“Close”键),调整好后将方式钮旋到现场再旋回停止(或按遥控器“Enter”键),此时bd闪烁两次表示波特率设置完成并退回上级菜单。

8.2 BD --- baud rate (default value --- 096)

Baud rate refers to the number of bits of data transmitted per second on the bus control loop, usually expressed in kilobytes / S (kilobits / second).

Move the menu item to "BD" and turn the mode button to the site and then turn it back to stop (or press the "enter" key of the remote control), that is, enter the baud rate setting. At this time, the parameter values 003-384 (003-0.3kb/s, 006-0.3kb/s, 012-1.2kb/s, 024-2.4kb/s, 048-4.8kb/s, 096-9.6kb/s, 192-19.2kb/s, 384-38.4kb / s) will be displayed in the lower left corner of the display screen. You can adjust the parameter values (or press the remote control button or Control "open" and "close" keys. After adjustment, turn the mode button to the site and then turn it back to stop (or press the "enter" key of the remote control). At this time, BD flashes twice to indicate that baud rate setting is completed and returns to the upper menu.

8.3 PA---校验位 (默认值---n2)

校验位是指总线控制回路上传送的数据中校验位的设置。

菜单项移至“PA”然后将方式钮旋到现场再旋回停止(或按遥控器“Enter”键),即进入校验位设置,此时显示屏左下角显示参数值O、E、n1、n2(O-奇校验、E-偶校验、n1-无校验和1位停止位、n2-无校验和2位停止位),可通过操作钮或调整参数值(或按遥控器“Open”、“Close”键),调整好后将方式钮旋到现场再旋回停止(或按遥控器“Enter”键),此时PA闪烁两次表示校验位设置完成并退回上级菜单。

8.3 PA --- check bit (default value --- N2)

Check bit refers to the setting of the check bit in the data transmitted on the bus control circuit.

Move the menu item to "pa" and then turn the mode button to the site and then turn it back to stop (or press the "enter" key of the remote control), that is, enter the calibration position setting. At this time, the parameter values o, e, N1, N2 (o-odd, e-even, n1-no calibration and 1-stop, n2-no calibration and 2-stop) are displayed in the lower left corner of the display screen. You can adjust the parameter values through the operation button or by pressing the remote control "open" And "close". After adjustment, turn the mode button to the site and then turn it back to stop (or press the "enter" key of the remote control). At this time, PA flashes twice to indicate that the check bit setting is completed and returns to the upper menu.

8.4 Lo---丢信时间 (默认值---010)

丢信时间是指执行器接收不到总线信号的容许时间。若超过此时间还接收不到总线信号,则判定为总线信号丢失,此时执行器将按照在高级设置中“丢信动作”项设定的要求进行动作。

菜单项移至“Lo”然后将方式钮旋到现场再旋回停止(或按遥控器“Enter”键),即进入校验位设置,此时显示屏左下角显示参数值O-199(0-199秒),可通过操作钮或调整参数值(或按遥控器“Open”、“Close”键),调整好后将方式钮旋到现场再旋回停止(或按遥控器“Enter”键),此时Lo闪烁两次表示丢信时间设置完成并退回上级菜单。

8.4 Lo --- lost time (default value --- 010)

The lost signal time refers to the allowable time when the actuator cannot receive the bus signal. If the bus signal is not received after this time, it is determined that the bus signal is lost. At this time, the actuator will act according to the requirements set in the "loss of signal action" item in the advanced settings.

Move the menu item to "Lo" and turn the mode button to the site and then turn it back to stop (or press the "enter" key of the remote control), that is, enter the calibration position setting. At this time, the parameter value o-199 (0-199 seconds) is displayed in the lower left corner of the display screen. You can turn the mode button to the site and then turn it back to stop (or press the remote control "open" and "close" key of the remote control) Enter), and lo flashes twice to indicate that the setting of the lost time is completed and returns to the upper menu.

8.报警信息说明(显示屏右下角为报警区)

8. Alarm information description (the lower right corner of the display is the alarm area)

故障码 Trouble code	故障信息 Fault information	故障码 Trouble code	故障信息 Fault information
FA	转向出错 Steering error	Fb	比例标定错误Fb闪烁3次 Proportion calibration error FB flashes 3 times
FC	关过矩 Closing moment	FO	开过矩 Opening moment
Fd	堵转或其它原因导致的 阀位不变化 No change of valve position due to locked rotor or other reasons	FP	电源缺相 Power missing phase
FS	DC4-20mA远控信号丢失 DC4-20ma remotecontrol signal lost	FH	远控开、关信号同在 Remote control on / off signal
FE	电机温度开关断开 或力矩公共端开路 Motor temperature switch open or torque common open	FF	阀位故障(电位器开路、 接线错或编码器故障) Valve position fault (potentiometer open circuit, wrong wiring or encoder fault)

9.常见问题处理方法

9. Solutions to common problems

通电指示灯和显示屏不显示 Power on indicator and display do not show	A.电源实际未接入 B.电压过低 C.接线错 D.电路坏 A. The power supply is not connected actually B. the voltage is too low C. the wiring is wrong D. the circuit is broken
工作中灯和显示屏显示异常 Abnormal display of working light and display	A.故障码 B.查询信息 C.指示灯或显示屏坏需更换电路 A. Fault code B. query information C. the circuit needs to be replaced if the indicator light or display screen is broken
通电现场和远控均不动作 Neither the power-on site nor the remote control will operate	A.接线错或开路 B.故障保护 C.电机坏或卡死 D.启动电容坏 E.电路坏 A. Wrong wiring or open circuit B. fault protection C. motor broken or stuck D. starting capacitance broken E. circuit broken
现场工作正常,但远控不动作 The scene works normally, but the remote control does not work	A.无信号或接线反 B.旋钮板坏或没在远方 C.正/反作用设错 D.电路坏 A. No signal or wiring is reversed B. knob board is broken or not in remote C. positive / negative reaction is set wrong D. circuit is broken
现场不动作,但远控工作正常 No action on site, but remote control works normally	A.旋钮板坏或没在现场模式 B.操作钮未旋到位 C.电路坏 A. The knob board is broken or not in the field mode B. the operating knob is not screwed in place C. the circuit is broken
能开不能关或能关不能开 Can open or close or can not close	A.力矩或行程开关开路 B.到限位或过矩 C.电机坏或堵转或接线错 D.电路坏 A. Torque or travel switch open circuit B. to limit or over torque C. motor broken or locked rotor or wrong wiring D. circuit broken
无控制信号,通电立即动作 No control signal, action immediately after power on	A.接线错 B.控制信号实际有效存在 C.丢信动作 D.设为两线控制 E.电路坏 A. Wiring error B. control signal is actually valid C. signal loss action D. set as two-wire control E. circuit failure
中间位置能动作到限位不动 The middle position can move to the limit	A.力矩开关接线错误 B.恰巧到位电机坏或接线开路 C.电路坏 A. Torque switch wiring error B. motor in place is broken or wiring is open C. circuit is broken
动作方向反 Reverse direction	A.电机接线反 B.阀位标定反 C.正/反作用或关闭方向设反 D.信号反 A. Motor wiring is reversed B. valve position calibration is reversed C. positive / negative action or closing direction is reversed D. signal is reversed
无比例反馈输出或时有时无 No proportional feedback output or sometimes none	A.输出接线错或接触不良 B.电位器或编码器故障或接触不良 C.电路坏 A. Wrong output wiring or poor contact B. potentiometer or encoder failure or poor contact C. circuit failure
比例反馈偏大或偏小或不变 Proportional feedback is too large or too small or constant	A.电位器或编码器故障 B.标定错 C.电位器与传动齿轮啮合不好 D.电路坏 A. Potentiometer or encoder fault B. wrong calibration C. poor engagement of potentiometer and transmission gear D. circuit failure

注：接线请严格按照电气接线图连接。

Note: please connect the wiring in strict accordance with the electrical wiring diagram.

注：本说明书如有更改恕不另行通知，如有疑问请联系供应商。

Note: This manual is subject to change without notice. If in doubt, please contact the supplier.