

Mobile: +86-15622261856

E-mail: sales@covnagroup.com

Web: www.covnagroup.com

ISO9001 CE RoHS 

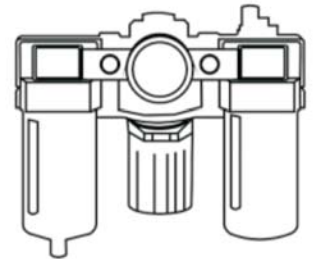
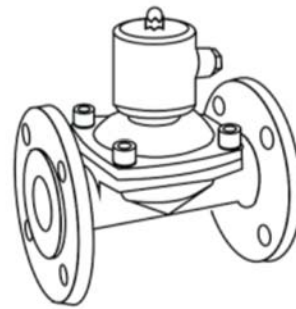
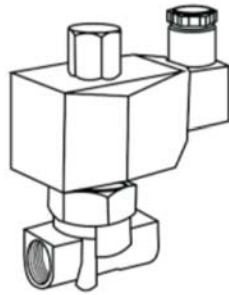
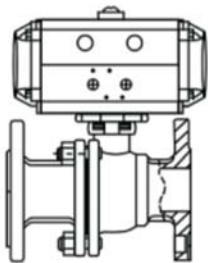

OPERATING MANUAL



Mini Electric Ball Valve

Main Parts Materials

NO.	Nane	material
1	Actuator	PPO AT20/AT100
2	Body Cover	STAINLESS STEEL 304
3	O-Ring	EPDM
4	Sealing	PTFE
5	Ball	STAINLESS STEEL 304
6	Stem	STAINLESS STEEL 304
7	O-Ring	EPDM

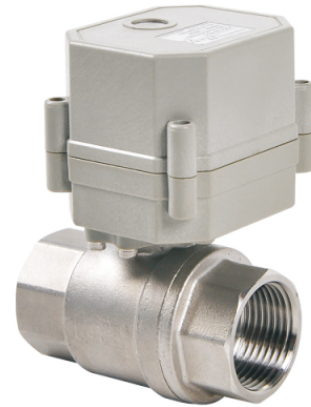

Outline Size Dimension

Size	T15(1/2")	T20(3/4")	T25(1")
D1/D2	1/2"	3/4"	1"
d	15	20	25
L1	63	72	81
L2	14	17	18
E1	25	31	38
H1	70	74	82
H2	17	20	24

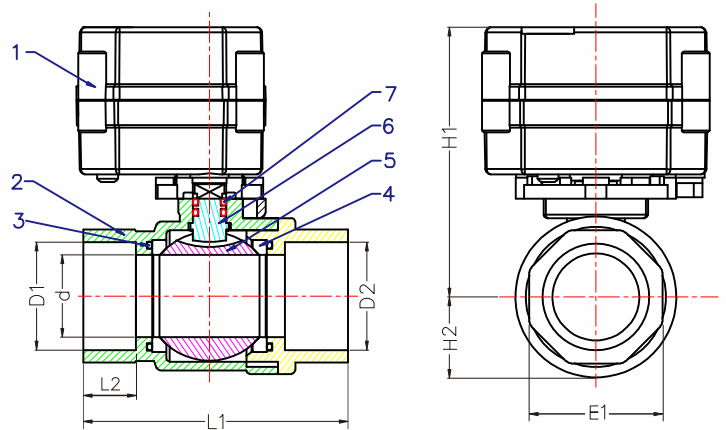

Technical Parameters

Product Specifications	DN15, DN20, DN25 (Optional)
Max. Working Pressure	1.0MPa
Circulation Medium	Water, Air
Rated Voltage	AC/DC 110-230V, DC9-24V (Optional)
Working Current	≤500mA
Open/Close Time	≤5S
Life Time	70,000 Times
Valve Material	Brass, SS304, SS316 (Optional)
Actuator Material	Engineering Plastics
Torque Output	2.0N.M
Ambient Temperature	-15°C-50°C
Liquid Temperature	2°C-90°C
Manual Override	NO
Indicator	YES
Line Control	CR2-01, CR2-02, CR3-01, CR3-02, CR3-03, CR4-01, CR5-01, CR5-02, CR7-01, CR7-02, CR7-03, CR7-04(Optional)
Gasket	PTFE
Sealing Material	FKM
Protection Class	IP67

Main Parts Materials

NO.	Name	material
1	Actuator	PPO AT20/AT100
2	Body Cover	STAINLESS STEEL 304
3	O-Ring	EPDM
4	Sealing	PTFE
5	Ball	STAINLESS STEEL 304
6	Stem	STAINLESS STEEL 304
7	O-Ring	EPDM



Outline Size Dimension

Size	T15(1/2")	T20(3/4")	T25(1")
D1/D2	1/2"	3/4"	1"
d1	12	15	18
L1	68	75	85
L2/L3	15	16	17
E1	24.5	31	38.5
H1	104	107	114.5
H2	18	18	23.5

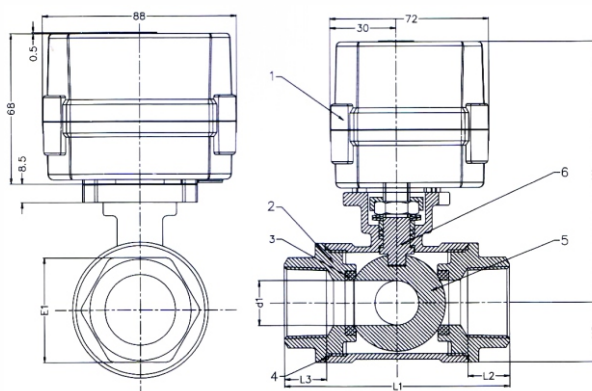

Technical Parameters

Product Specifications	DN20, DN25 (Optional)
Max. Working Pressure	1.0MPa
Circulation Medium	Water, Air
Rated Voltage	DC5V, AC/DC 110-230V, DC9-35V (Optional)
Working Current	≤ 800mA
Open/Close Time	≤ 15S
Life Time	70,000 Times
Valve Material	Brass, SS304, SS316 (Optional)
Actuator Material	Engineering Plastics
Torque Output	10.0NM
Ambient Temperature	-15°C-50°C
Liquid Temperature	2°C-90°C
Manual Override	Optional
Indicator	YES
Line Control	CR2-01, CR2-02, CR3-01, CR3-02, CR3-03, CR4-01, CR5-01, CR5-02, CR7-01, CR7-02, CR7-03, CR7-04 (Optional)
Gasket	PTFE
Sealing Material	EPDM
Protection Class	IP67

T型通口 T-shaped Passage

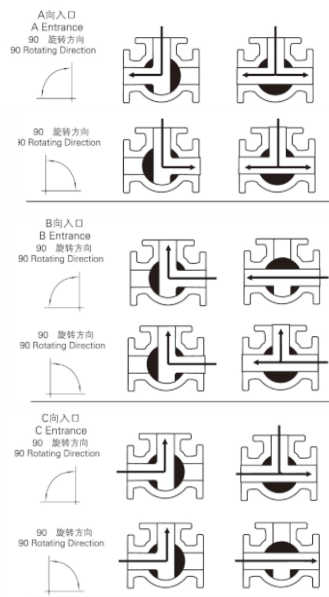

L型通口 L-shaped Passage

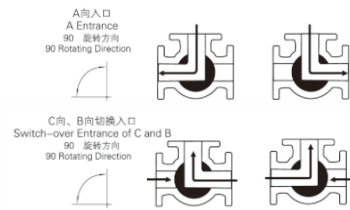

Main Parts Materials

NO.	Name	material
1	Actuator	PPO AT20/AT100
2	Body Cover	BRASS
3	O-Ring	EPDM
4	Sealing	PTFE
5	Ball	BRASS
6	Stem	BRASS
7	O-Ring	EPDM



Outline Size Dimension

Size	T15(1/2")	T20(3/4")	T25(1")	T32(1-1/4")
D1/D2	1/2"	3/4"	1"	1-1/4"
d	15	20	24	25
L1	56	66	71	79
L2	13	15	15	20
E1	25	31	38	46
H1	84	87	89	91
H2	16	19	22	25

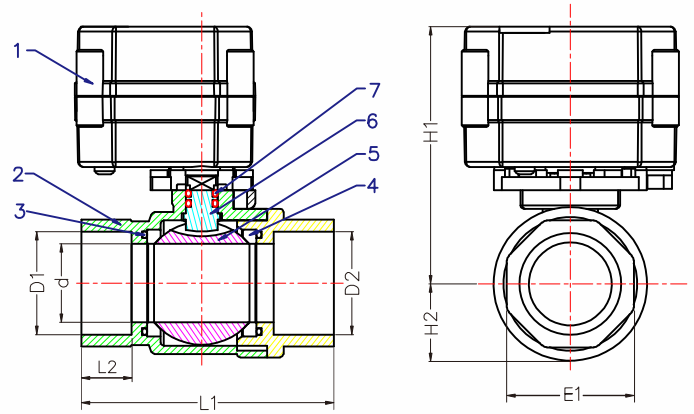

Technical Parameters

Product Specifications	DN15, DN20, DN25 (Optional)
Max. Working Pressure	1.0MPa
Circulation Medium	Water, Air
Rated Voltage	AC/DC 110-230V, DC9-24V (Optional)
Working Current	≤500mA
Open/Close Time	≤5S
Life Time	70,000 Times
Valve Material	Brass, SS304, SS316 (Optional)
Actuator Material	Engineering Plastics
Torque Output	2.0N.M
Ambient Temperature	-15°C-50°C
Liquid Temperature	2°C-90°C
Manual Override	NO
Indicator	YES
Line Control	CR2-01, CR2-02, CR3-01, CR3-02, CR3-03, CR4-01, CR5-01, CR5-02, CR7-01, CR7-02, CR7-03, CR7-04(Optional)
Gasket	PTFE
Sealing Material	FKM
Protection Class	IP67

Main Parts Materials

NO.	Name	material
1	Actuator	PPO AT20/AT100
2	Body Cover	BRASS
3	O-Ring	EPDM
4	Sealing	PTFE
5	Ball	BRASS
6	Stem	BRASS
7	O-Ring	EPDM



Outline Size Dimension

Size	T15(1/2")	T20(3/4")	T25(1")
D1/D2/D3	1/2"	3/4"	1"
d1	15	15	24
W1	7	7	8
L1	56	66	75
L2	13	16	17
L3	3	3	4
H1	73.5	71	77
H2	27	31	38.5

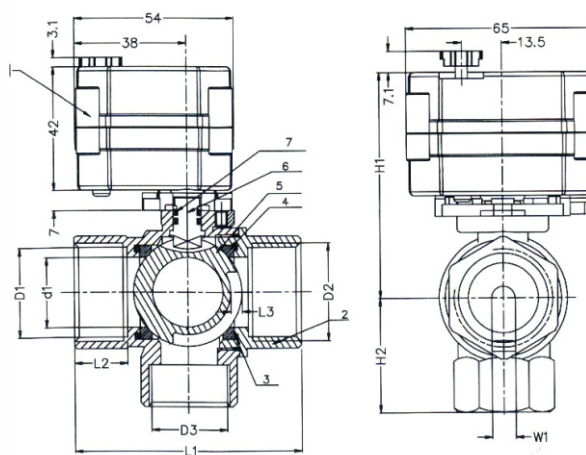

Technical Parameters

Product Specifications	DN20, DN25 (Optional)
Max. Working Pressure	1.0MPa
Circulation Medium	Water, Air
Rated Voltage	DC5V, AC/DC 110-230V, DC9-35V (Optional)
Working Current	≤ 500mA
Open/Close Time	≤ 5S
Life Time	70,000 Times
Valve Material	Brass, SS304, SS316 (Optional)
Actuator Material	Engineering Plastics
Torque Output	2.0NM
Ambient Temperature	-15°C-50°C
Liquid Temperature	2°C-90°C
Manual Override	Optional
Indicator	YES
Line Control	CR2-01, CR2-02, CR3-01, CR3-02, CR3-03, CR4-01, CR5-01, CR5-02, CR7-01, CR7-02, CR7-03, CR7-04 (Optional)
Gasket	PTFE
Sealing Material	EPDM
Protection Class	IP67

T型通口 T-shaped Passage

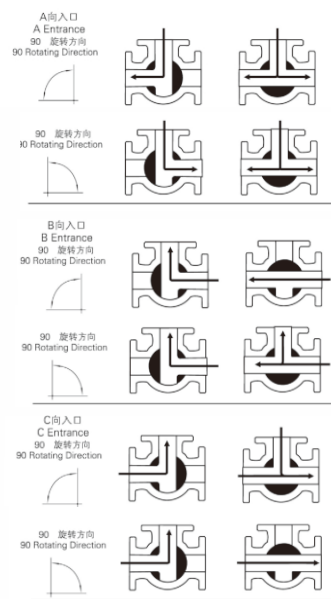

L型通口 L-shaped Passage

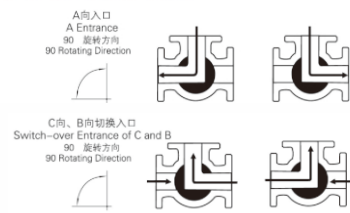

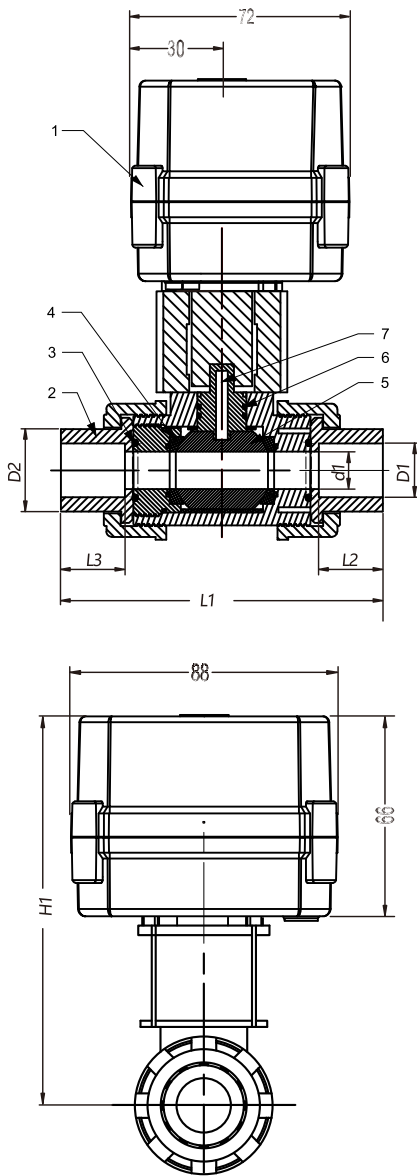
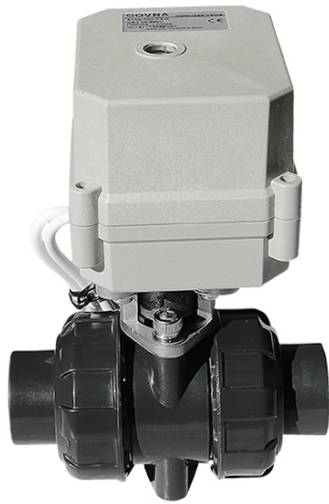

Design Feature

- All-copper gear design, high accuracy output torque, especially for multi-channel scaling system.
- Small size, compact structure.
- A variety of control methods, either to accept remote valve position control signal, but also the feedback Signal in place for computer intelligence unit testing.
- Good sealing performance

Miniature Motorized UPVC Ball Valve

Product Specification	1/2", 3/4", 1", NPT/BSP (Optional)
Max. Working Pressure	1.0MPa
Circulation Medium	Fluid, Air
Rated Voltage	AC/DC9~24V, AC110-230V (Optional)
Working Current	≤ 800mA
Open/Close Time	≤ 15 Sec
Life Time	70,000 times
Actuator Material	Engineering Plastics
Valve Body Material	UPVC
Sealing Material	PTFE
Actuator Rotation	90°
Max. Torque Output	10N.M
Ambient Temperature	-15°C ~ 50°C
Liquid Temperature	2°C ~ 90°C
Line Control	CR2-01, CR2-02, CR3-03, CR4-01, CR5-01, CR5-02, CR7-03, CR7-04 (Optional)
Cable Length	0.5m, 1.5m(Optional)
Manual Override	No
Indicator	Yes
Protection Class	IP67

Main Parts Materials

No.	Parts	Material	Quantity
1	Actuator	PPO	1
2	Body	Stainless Steel	1
3	O-ring	FKM	2
4	Sealing	PTFE	2
5	Ball	Stainless Steel	1
6	O-ring	FKM	2
7	Stem	Stainless Steel	2

Outline Size Dimension

Size	d1	D1	D2	L1	L2	L3
HKT15(1/2")	15	20	34	99	21	21
HKTs20(3/4")	20	25	40	117	25	25
HKT25(1")	25	32	47	132	29	29

Main Parts Materials

NO.	Name	material
1	Actuator	PPO AT20/AT100
2	Body Cover	BRASS
3	O-Ring	EPDM
4	Sealing	PTFE
5	Ball	BRASS
6	Stem	BRASS
7	O-Ring	EPDM



Outline Size Dimension

Size	T15(1/2")	T20(3/4")	T25(1")
D1/D2	1/2"	3/4"	1"
d1	15	20	25
L1	63	72	81
L2	14	17	18
E1	25	31	38
H1	83	87	95
H2	17	20	24

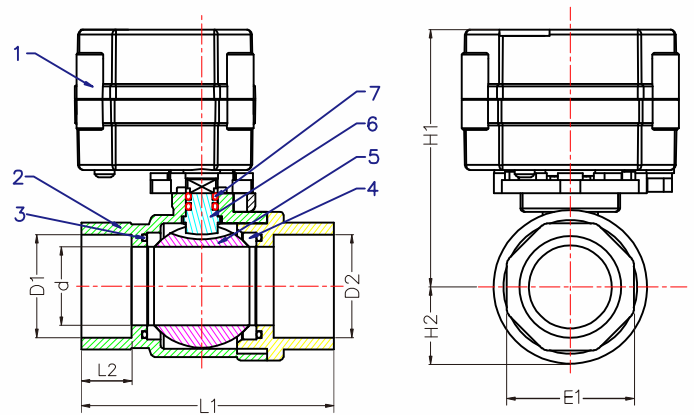

Technical Parameters

Product Specifications	DN15, DN20, DN25 (Optional)
Max. Working Pressure	1.0MPa
Circulation Medium	Water, Air
Rated Voltage	AC/DC 110-230V, DC9-24V (Optional)
Working Current	≤ 80mA
Open/Close Time	≤ 7S
Life Time	100,000 Times
Valve Material	Brass, SS304, SS316 (Optional)
Actuator Material	Engineering Plastics
Ambient Temperature	-15°C-50°C
Liquid Temperature	2°C-90°C
Manual Override	NO
Keeping Valve Open Time	0H:0M:0S-99H:59M:59S
Indicator	YES
Sealing Material	SEPDM

Main Parts Materials

NO.	Name	material
1	Actuator	PPO AT20/AT100
2	Body Cover	STAINLESS STEEL 304
3	O-Ring	EPDM
4	Sealing	PTFE
5	Ball	STAINLESS STEEL 304
6	Stem	STAINLESS STEEL 304
7	O-Ring	EPDM



Outline Size Dimension

Size	T15(1/2")	T20(3/4")	T25(1")
D1/D2	1/2"	3/4"	1"
d1	15	20	25
L1	63	72	81
L2	14	17	18
E1	25	31	38
H1	83	87	95
H2	17	20	24

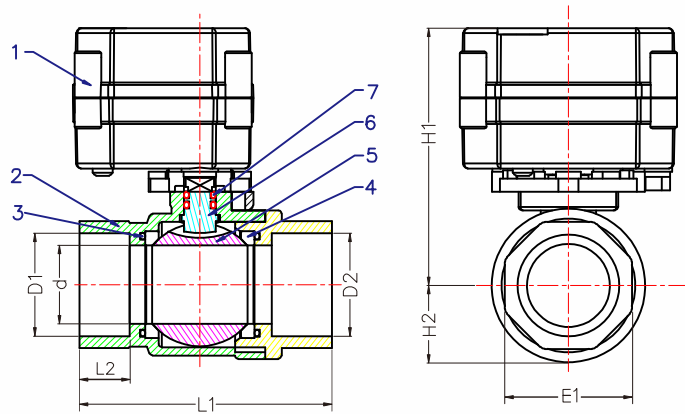

Technical Parameters

Product Specifications	DN15, DN20, DN25 (Optional)
Max. Working Pressure	1.0MPa
Circulation Medium	Water, Air
Rated Voltage	AC/DC 110-230V, DC9-24V (Optional)
Working Current	≤ 80mA
Open/Close Time	≤ 7S
Life Time	100,000 Times
Valve Material	Brass, SS304, SS316 (Optional)
Actuator Material	Engineering Plastics
Ambient Temperature	-15°C-50°C
Liquid Temperature	2°C-90°C
Manual Override	NO
Keeping Valve Open Time	0H:0M:0S-99H:59M:59S
Indicator	YES
Sealing Material	SEPDM

AT20 Outline Size Dimension

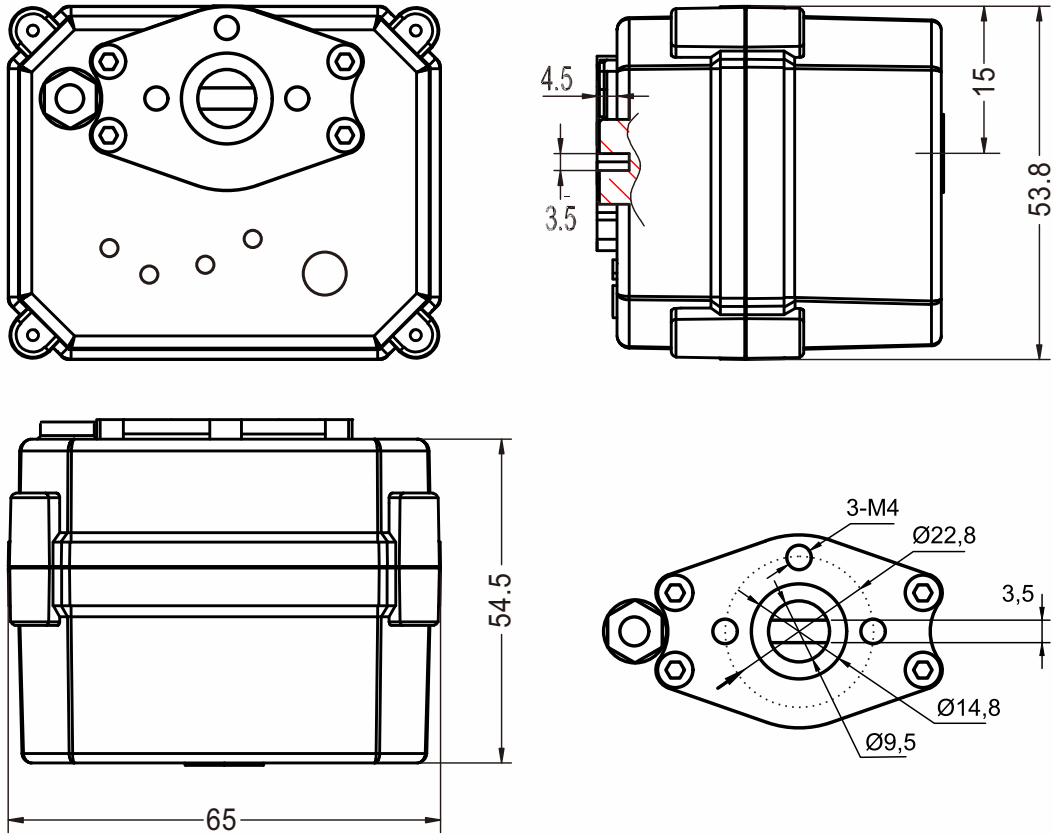

AT100 Outline Size Dimension

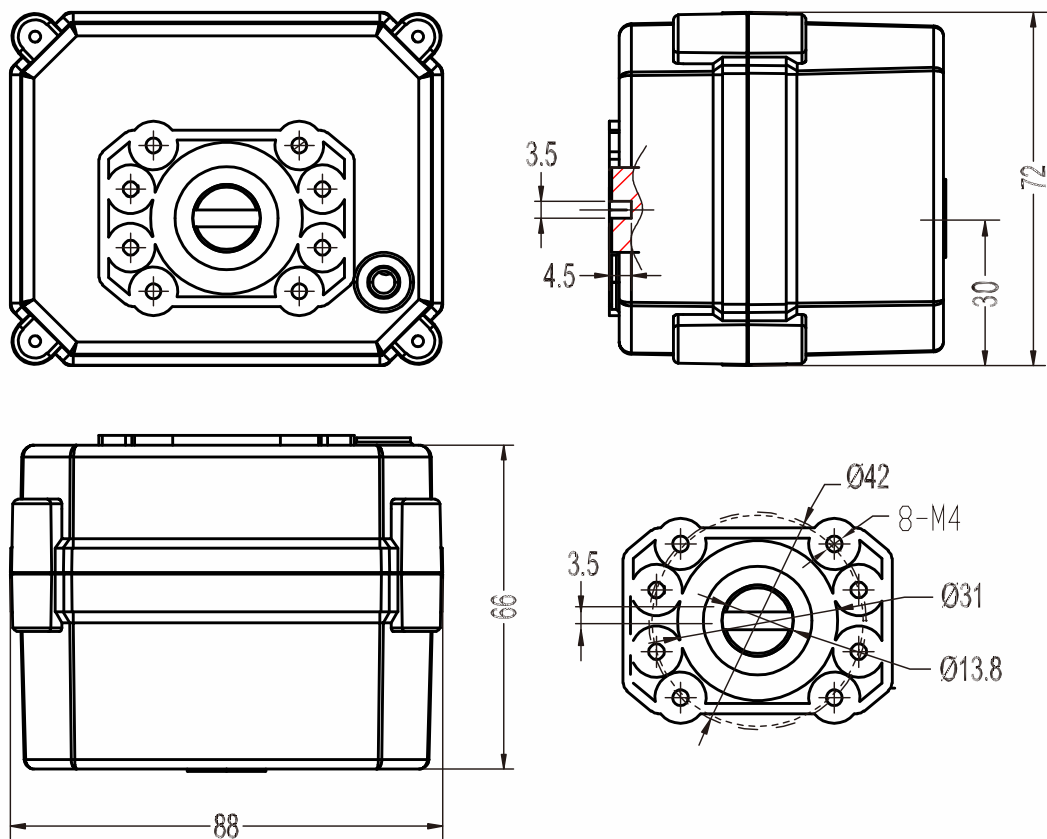



HK20-S-A Series

- Indicator
- Manual Override



HK20-S-B Series

- Indicator
- Manual Override



HK20-S-C Series

- Indicator
- Manual Override

CR2 01 Wiring Diagram (2 wires control)

- 1, RD connect with positive, the BK connect with negative, the valve closed, the actuator automatically power off after in place , the valve remains fully closed position
- 2, BK connect with positive, the RD connect with negative, the valve open, the actuator automatically power off after in place, the valve remains fully open position .

- * Suitable Working Voltage: DC5V/DC12V/DC24V
- * Exceeding the working voltage is forbidden

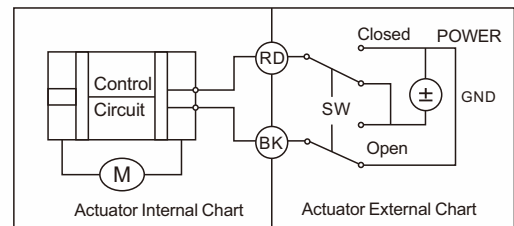

CR2 02 Wiring Diagram (2 wires control – Spring return in case of the power failure)

- 1, When SW is closed , the valve open. the actuator automatically power off after in place
- 2, When SW is open, the valve closed, the actuator automatically power off after in place

- * Suitable Working Voltage: AC/DC9-35V
- * Exceeding the working voltage is forbidden

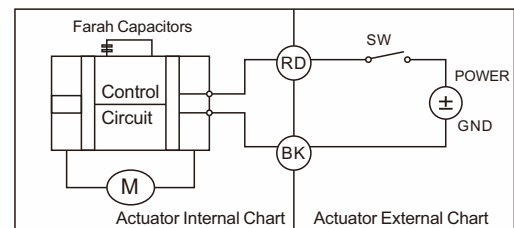

CR3 01 Wiring Diagram (3 wires control)

- 1, RD & GR connect with positive, BK connect with negative
- 2, When OPEN (RD) & SW connected, the valve open, the actuator automatically power off after in place, valve remains fully open position
- 3, When CLOSE (GR) & SW connected, the valve closed, the actuator automatically power off after in place, valve remains fully closed position

- * Suitable Working Voltage: DC5V, DC12V, DC24V
- * Exceeding the working voltage is forbidden

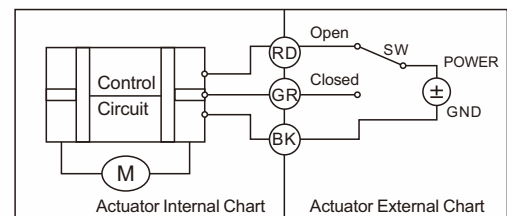

CR3 02 Wiring Diagram (3 wires control)

- 1, RD connect with positive, the BK & GR connect with negative
- 2, SW CLOSED, the valve OPEN, the actuator automatically power off after in place.
- 3, SW OPEN, the valve CLOSED, the actuator automatically power off after in place.

- * Suitable Working Voltage: DC9V-35V
- * Exceeding the working voltage is forbidden

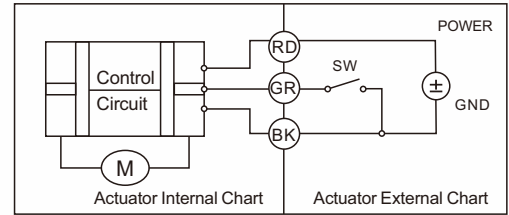

CR3 03 Wiring Diagram (3 wires control)

- 1, RD& GR connect with positive, the BK connect with negative
- 2, SW CLOSED, the valve OPEN, the actuator automatically power off after in place
- 3, SW OPEN, the valve CLOSED, the actuator automatically power off after in place.

- * Suitable Working Voltage: AC/DC9-35V/AC110-230V
- * Exceeding the working voltage is forbidden

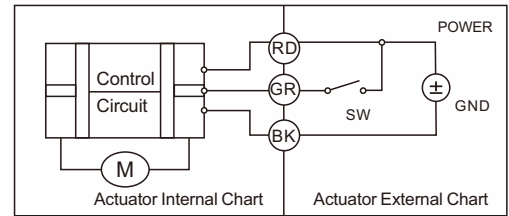

CR3 04 Wiring Diagram (3 wires control)

- 1, RD & GR connected with positive, and the BK connected with negative
- 2, When RD & SW connected, the valve closed, the actuator automatically power off after in place , remains fully closed position
- 3, When GR & SW connected, the valve open, the actuator automatically power off after in place, remains fully open position

- * Suitable Working Voltage: DC5V, DC12V, DC24V, AC/DC9-35V
- * Exceeding the working voltage is forbidden

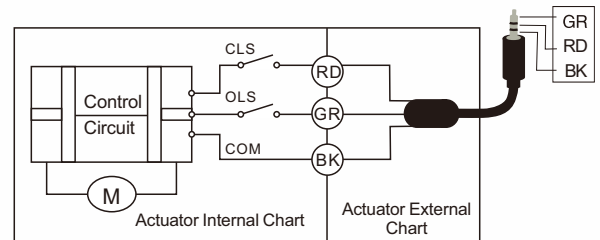

CR3 05 Wiring Diagram(3 wires control)

- 1, RD connect with positive, GR connect with SW & positive
- 2, BK connect with negative
- 3, When the SW of GR closed, the valve closed, the actuator automatically power off after in place , remains fully closed position
- 4, When the SW of GR open, the valve open, the actuator automatically power off after in place , remains fully open position

- * Suitable Working Voltage: DC5V/DC12V/DC24V
- * Exceeding the working voltage is forbidden

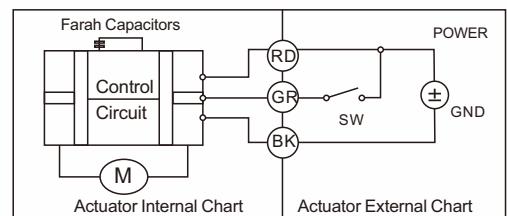

CR3 06 Wiring Diagram(3 wires control)

- 1, RD connect with positive, GR connect with SW & positive
- 2, BK connect with negative
- 3, When the SW of GR closed, the valve open, the actuator automatically power off after in place , remains fully closed position
- 4, When the SW of GR open, the valve closed, the actuator automatically power off after in place , remains fully open position.

- * Suitable Working Voltage:DC12V, DC24V,AC/DC9-35V,AC110-230V
- * Exceeding the working voltage is forbidden

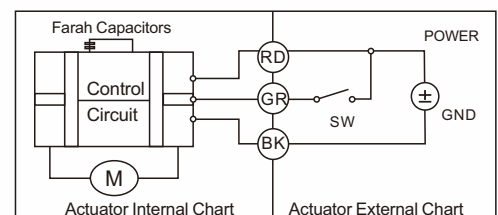

CR4 01 WIRING DIAGRAM(4 WIRES CONTROL)

- 1, RD&BK are connected to the power, WT&YW are connected to the controlled wiring.
- 2, When the sw is closed, the valve open
- 3, When the sw is open, the valve closed
- 4, Suitable working voltage:AC110v-230V5,
- 5, Exceeding the working voltage is forbidden

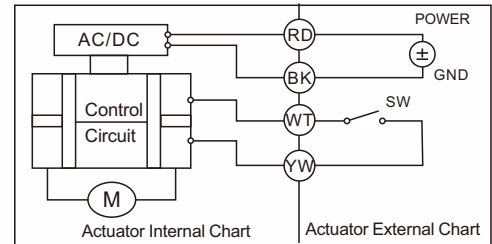

CR5 01 WIRING DIAGRAM (WITH FEEDBACK SIGNAL)

- 1, RD connect with positive, the BK connect with negative, the valve closed, the actuator automatically power off after in place
- 2, BK connect with positive, the RD connect with negative, the valve open, the actuator automatically power off after in place
- 3, BL & WT are connect when the valve open fully, YW&WT are connect when the valve closed fully
- * Suitable Working Voltage: DC12V,DC24V
- * Exceeding the working voltage is forbidden

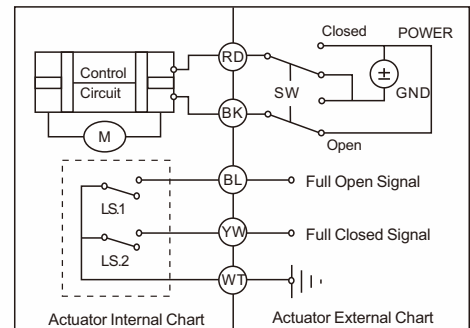

CR502 WIRING DIAGRAM (5 wires control , with feedback signal)

- 1, When SW is closed , the valve open. the actuator automatically power off after in place
- 2, When SW is open, the valve closed, the actuator automatically power off after in place BL & WT are connect when the valve open fully, YW & WT are connect when the valve closed fully
- * Suitable Working Voltage: AC/DC9-24V, AC/DC110V-230V,
- * Exceeding the working voltage is forbidden

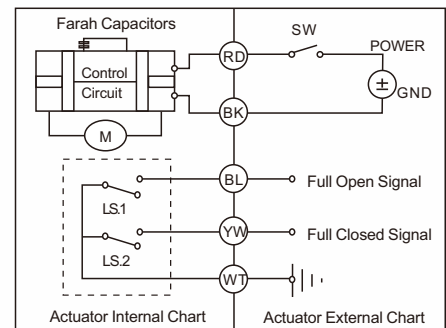

CR7 01 WIRING DIAGRAM (7 WIRES CONTROL WITH FEEDBACK SIGNAL)

- 1, RD connect with positive
- 2, GR connect with SW and negative wiring
- 3, BK connect with negative wiring
- 5, SW closed. the valve closed, and keeping fully closed.
- 6, BL & GY connect with the valve's fully open signal wiring
- 7, YW & WT connect with the valve's fully closed signal wiring.
- * Suitable Working Voltage: DC9V-35V
- * Exceeding the working voltage is forbidden
- * Feedback with load ability

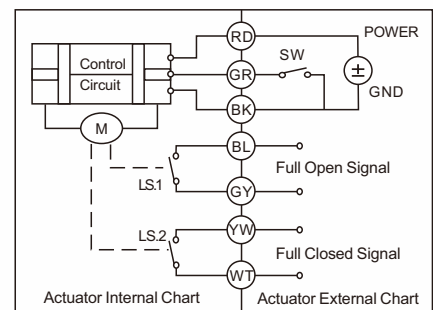

- ①The Max. off voltage: DC36V AC220V
- ②The Max. off current: 0.4A

CR7 02 Wiring Diagram (7 wires control with feedback signal)

1. RD & GR connect with positive, the BK connect with negative
 2. When RD & SW connected, the valve open, the actuator automatically power off after the valve fully open.
 3. When GR & SW connected, the valve closed, the actuator automatically power off after the valve fully closed.
 4. BL & GY connect with the valve's fully open signal wiring
 5. YW & WT connect with the valve's fully closed signal wiring
- * Suitable Working Voltage: DC5V, DC12V, DC24V, AC/DC9-35V
 - * Exceeding the working voltage is forbidden
 - * Feedback with load ability

①The Max. off voltage: DC36V AC220V ②The Max. off current: 0.4A

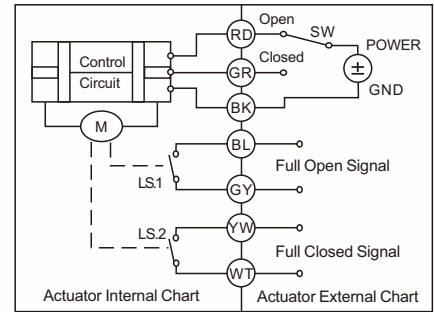

CR7 03 Wiring Diagram (7 wires control with feedback signal)

- 1, RD& GR connect with positive, the BK connect with negative
 - 2, SW CLOSED, the valve OPEN, the actuator automatically power off after in place
 - 3, SW OPEN, the valve CLOSED, the actuator automatically power off after in place
 - 4, BL & GY connect with the valve's fully open signal wiring
 - 5, YW & WT connect with the valve's fully closed signal wiring.
- * Suitable Working Voltage: DC12V, DC24V
 - * Exceeding the working voltage is forbidden

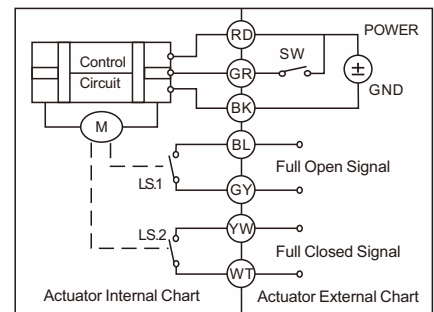

CR7 04 Wiring Diagram (7 wires control with feedback signal)

- 1, RD & BK are connected to the power, WT & YW are connected to the controlled wiring.
 - 2, When the SW is closed , the valve open
 - 3, When the SW is open , the valve closed
 - 4, BL & GY connect with the valve's fully open signal wiring
 - 5, YW & WT connect with the valve's fully closed signal wiring.
- * Suitable Working Voltage: AC/DC110V-230V
 - * Exceeding the working voltage is forbidden

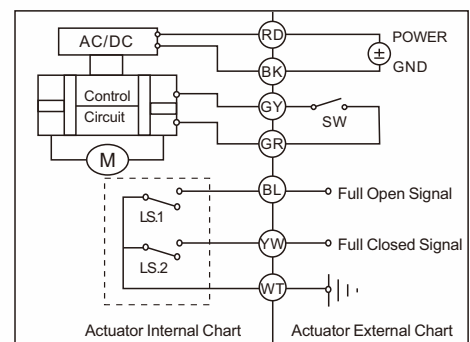

Manual override instructions:

In case of an electric supply failure, it is possible to operate the actuator manually:

- 1, Power must in off position when start the manual override.
- 2, Gently pull up the knob about 3mm, then revolve the knob around left and right to control the valve open or close.
- 3, When the red needle in the indicator pointing to S, means the valve is closed. When pointing to 0, means the valve is open.
- 4, After finish the manual override operation, must press down the knob, so that for the normal electric operation.



Parameter specifies

Working voltage :AC110–230V/AC/DC9–24V

The time for keeping valve open :0 H : 0M :0S --99 H 59 M 59 S

The time for keeping valve closed : 0 H : 0M :0S --99 H 59 M 59 S

Timer specification

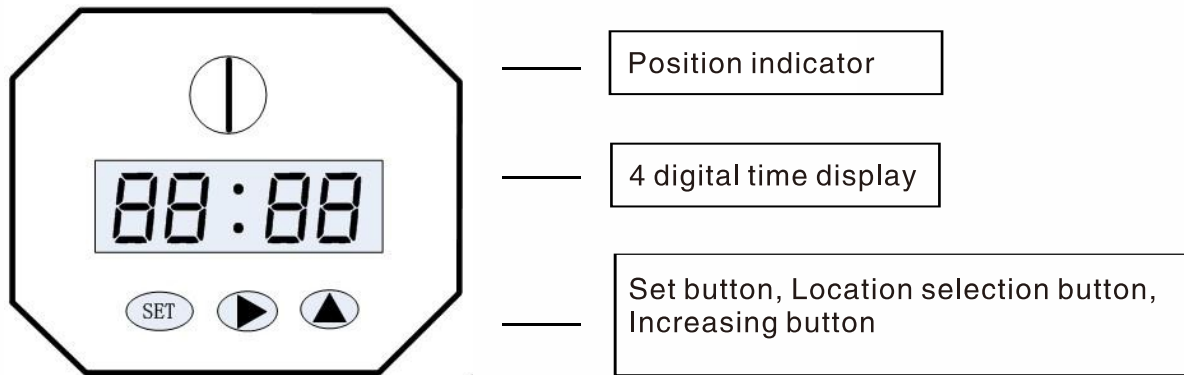

Operation instruction

Actuator parameter setting have twomenu structures on below:

Function code (firstmenu),

The setting parameters of function code (secondarymenu)

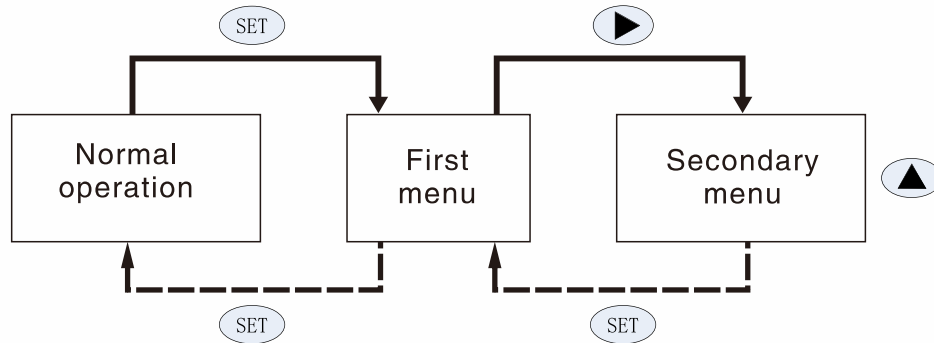

Picture 0 Secondarymenu operationmenu

Function code	Content	Value	Unit	Remarks
T ON	valve keeping open time	00:00:00–99:59:59	H:M:S	–
T OFF	valve keeping closed time	00:00:00–99:59:59	H:M:S	–
PONS	Power –on Action	ON/OFF	–	–
PROT	Stall current setting	0–599	MA	When the current is bigger than the setting value 1.6S, the motor will stop working , and the display will show Err.

Parameter function control table

① Press **SET** 2 seconds and enter to first menu, the screen display picture 1 text (t on) , indicating enter to set the valve keeping open state .

Press **SET** again, the screen display picture 2 text (t o FF) , indicating enter to set the valve keeping closed state .

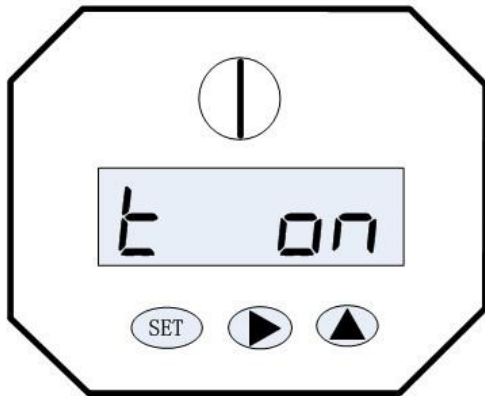

Picture 1

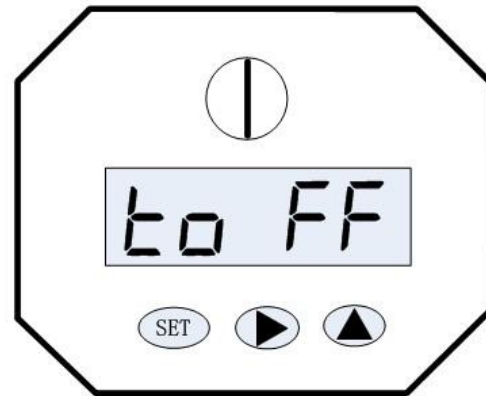

picture 2

② Press then **▶** the after entering the setting state , showing the valve keeping time for setting (Set the valve keeping open time on the valve keeping open state . Set the valve keeping closed time on the valve keeping closed state.) . Select flashing bit by pressing , **▶** and change the numerical by pressing **▲** .

When " : " is flashing , indicate setting "HS (hours) :MS(minutes)" , and change the flashing bit by pressing **▶**

When the " : " is bright , indicate setting " MS(minutes) :SS(seconds) " .

The data will be deposited in the valve controller after completing the setting .

Press **SET** when finish setting , will return fist menu , press **SET** again , enter to next fist menu to set parameters .



Picture 3



picture 4

- ③ Press the **SET** & **▶** , the screen display picture 5 , indicating open the valve manually .
 Press the **SET** & **▲** , the screen display picture 6, indicating closed the valve manually .
 Exit manual mode to press the **SET** & **▶** or **SET** & **▲** . And go the power –onaction .

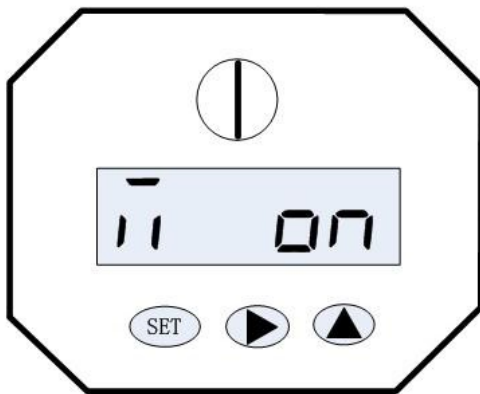

Picture 5

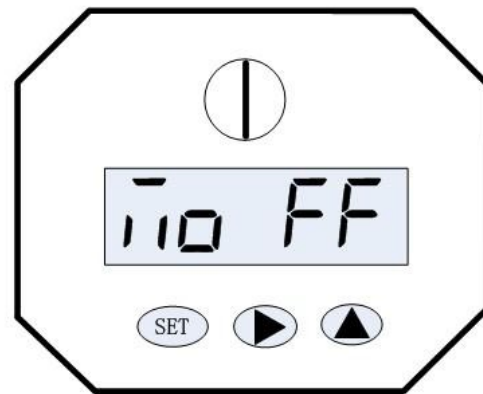

picture 6

- ④ On the normal working state, the displayed time is valve keeping time.(e.g. Valve keeping open time is 10 S, will count down 10S)
 The " : " is flashing , indicating the "HS (hours) : MS(minutes)" .
 The " : " is bright, indicating the " MS(minutes) : SS(seconds) " .

Stalling protection function

When the actuator is detected stalling, it will run in reverse direction .when reach to the open or closed position , and do the close or open action again , meanwhile displaying flashed 0000–0001 on screen (indicating the current retrying times) . If it fail at third retrying , the valve will stop running and display ERR1 on the screen .

Common faults and inspection, troubleshooting

Fault Resolution	Possible Causes	Solution
The valve body does not operate after power is applied, The display is on.	Valve body on / off hold time is not reached	Check whether the display on / off hold time is too long and enter the level menu to shorten the time
	The body has debris jammed or blocked	Check whether the display shows ERR1, if any display please clean up sediment
	Water pressure is higher than valve body torque	Go to the primary menu Prot, increase the current to increase the torque
The valve body does not operate after power is applied, The display is off.	no power on	Check if the line is powered on
	There's water in the actuator, Circuit board short circuit	Contact the salesperson
	Not used in the normal voltage range, the circuit board burned	Contact the salesperson
The valve body does operate after power is applied, the timer can not be set.	Internal button failure	Contact the salesperson

SOLENOID VALVE



ELECTRIC VALVE



PNEUMATIC VALVE



SPECIALIZED FLUID CONTROL VALVE MANUFACTURER