

### 一、什么是爆炸？

引发爆炸的先决条件是易爆物质必须与氧气有一定程度的混合，在适当的引燃条件下引起化学反应。如果反应速度超过声速，就被定义为爆炸。

积累到一定程度的易爆混合物突然爆炸，并以爆炸波的形式造成破坏效应。

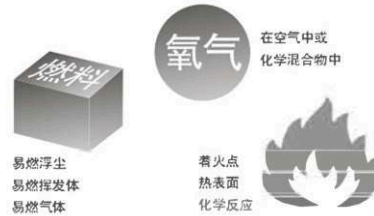

### 二、什么是防爆？

上述三个条件之中的任何一个被限制发生，就能防止爆炸。在许多使用现场，易爆物质以及氧气的存在是很难避免的，因此引燃源必须要受到限制。

电气设备是一个潜在的引燃源，在机器运转时导致表面温度升高、静电释放或瞬间电流所引起的电火花等。

在设计上，防爆型电气设备避免了在其运转过程中表面温度过高和引起电火花。因此，防爆型电气设备不会成为潜在的引燃源。



### 三、潜在的易爆环境分级

通常爆炸性气体环境用电气设备可分为两类：

I类煤矿用电气设备；

II类除煤矿外的其它爆炸性气体环境用电气设备。

对于II类电气设备，按照爆炸性气体的最大试验安全间隙（隔爆型）和最小试验引燃电流（本安型）可分为：IIA、IIB、IIC三个爆炸级别，且IIB类设备可适用于IIA设备的使用条件，IIC类设备可适用于IIA及IIB设备的使用条件。

对于II类电气设备，按照允许的最高表面温度可分为T1(450℃)、T2(300℃)、T3(200℃)、T4(135℃)、T5(100℃)、T6(85℃)等六个温度组别，且高一温度组别的设备可适用于低一温度组别的使用条件。

90%以上的爆炸性气体包含在IIA、IIB的爆炸级别和T1-T4的温度组别当中。

		温度组别					
		T1 (450℃)	T2 (300℃)	T3 (200℃)	T4 (135℃)	T5 (100℃)	T6 (85℃)
爆炸级别	IIA	丙酮、乙烷、氨、苯、乙酸、甲醇、丙烷、甲苯……	乙醇、丁烷、丁醇、乙烯、二氯乙烷……	苯、柴油、航空燃油、乙烷、燃油……	乙醛		
	IIB	燃气	乙烯、乙烯氧		乙醚		
	IIC	氢	乙炔				碳、二硫化物

### 四、如何实现防爆？

可以有不同的方法使得电气设备适用于易爆的环境中，在GB3836、IEC60079、EN50014等标准中对这些方法均有详尽的描述。

BYS防爆系列电动执行机构按防爆类型为“隔爆型”（Exd）的型式制造，符合GB3836.1-2010、GB3836.2-2010标准要求。

#### 隔爆型（Exd）

隔爆型执行机构允许在设备内部发生爆炸，壳体的隔爆面是按照阻止内部火花或爆炸载体与外界发生接触来设计的，合适的隔爆面间隙的足够大的隔爆面长度可确保这一点。同时，坚固的壳体可以承受内部爆炸产生的高压而不被破坏。

COVNA HK防爆系列执行机构以下部件是按隔爆型标准来设计和制造：

- ◆电机腔 ◆电气元件腔 ◆接线腔

#### 防爆等级

COVNA HK防爆系列电动执行机构的防爆等级为：

ExdIIBT6Gb

Ex-防爆标识

d-防爆类型，表示为“隔爆型”；

II-设备类别，表示除煤矿外的其它爆炸性气体环境用电气设备；

B-爆炸级别，该级别决定执行机构各隔爆接合面的尺寸（长度和间隙）；

T6-温度组别，表示允许执行机构最高表面温度为80℃；

Gb-表示设备保护级别。



1. Product Overview

HK-EXCT6-EX series explosion-proof electric actuators are a new generation of products developed with the latest technology from abroad with unique design and new style. It has the characteristics of high intelligence, high protection performance, small volume, high integration, long service life and stable performance. But field operation, too glume n. With remote control, suitable for control of 0° ~ 270° rotary valves and other similar products. Such as butterfly valve, ball valve, air valve Baffle valve, stopcock valve, louver valve and other equipment suitable for 0~270° rotation. It can meet the requirements of industrial automation control management. It is driven by a 380V/220V/110V AC power supply and is controlled by a 4-20Ma current signal or a 0-10VDC voltage signal. The valve can be moved to the desired position to achieve its automatic control, maximum output torque up to 3000N.M. Widely used in petroleum and chemical industry, Industrial, Gold, Water Treatment, Shipping, Paper, Power Plant, Printing and Dyeing, Food Processing, Pharmaceutical and Building Automation Systems and many other industries.

2. Product characteristics

1. Strong function: intelligent adjustment type, proportional type, switch type, all kinds of signal output type are all available;
2. Light body size: the volume and weight are only about 35% of the traditional products;
3. Beautiful and generous: aluminum alloy die-casting shell, exquisite and smooth, and can reduce electromagnetic interference;
4. Reliable performance: bearings and electrical components and other key components are imported famous brand products;
5. High standard protection: IP68 high standard protection grade
6. Precision wear resistance: worm gear output shaft integrated special copper alloy forging, high strength, good wear resistance;
7. The return difference is very small: the structure avoids the gap of key connection and has high transmission accuracy.
8. Safety guarantee: through 1500V voltage resistance test, F class insulated motor, safety is guaranteed;
9. The matching is simple: using single-phase power supply, simple external line, can also do 380V, DC power supply;
10. Convenient to use: no refueling, no point inspection, waterproof and rust prevention, arbitrary angle installation;
11. Multiple speeds: the whole process time is 3 seconds, 9 seconds, 13 seconds, 15 seconds, 30 seconds, 50 seconds, 100 seconds, 150 seconds (set before the factory);
12. Intelligent numerical control: intelligent control module is integrated into the body of electric actuator, without external locator, digital setting, digital Setting, high accuracy, self-diagnosis, machine multi-ability.
13. The intelligent electric actuator adopts integrated and modular technology, which has the characteristics of reliable performance and complete function. Set position inversion Feed, servo amplification in one, and adjustment and use is particularly convenient, wiring is particularly simple, and can expand the communication interface.
14. It has the function of field digital display and manual operation: the actuator control module has a digital display screen, which can display the opening of the actuator; and can carry on the field operation through the key on the control module.
15. There is menu setting function: the intelligent control module has menu setting key, through which the actuator control mode can be set at will. Control accuracy, protection measures, etc.
16. Self-adjusting function: after the electric stroke (electrical zero, full position) of the actuator is determined, the actuator can automatically calibrate the electrical zero.
17. There is a program to set the upper and lower limits of the function: you can set the upper and lower limits of the actuator stroke by keystrokes.
18. It has the function of setting the action mode of the actuator: the actuator can choose to turn on and stop the actuator in the case of broken signal. It's all closed in three states.
19. There is the function of electronic brake: when the actuator needs to stop running, the control module outputs a reversal signal to realize the electronic brake.
20. Error code fault function: when the actuator fails, the control module display screen displays the error code, indicating the cause of the fault.

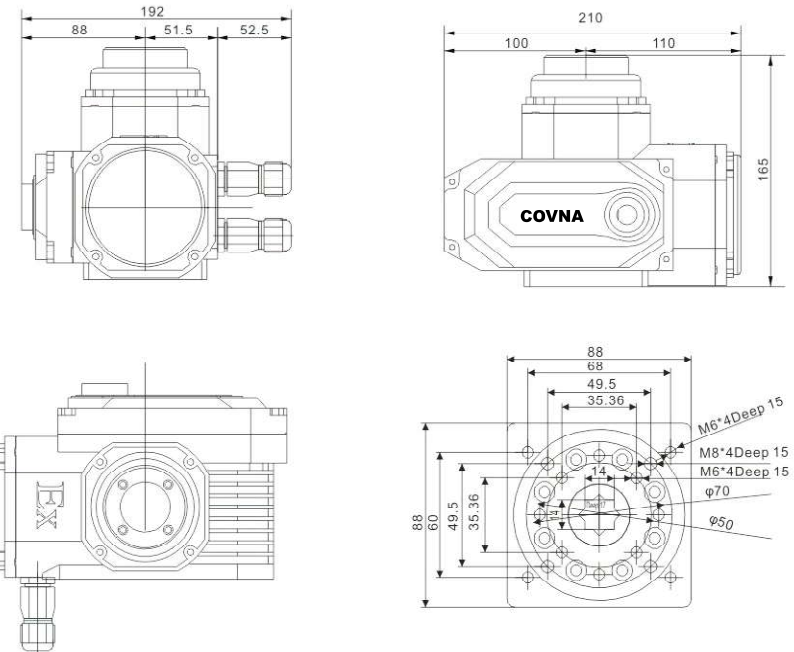

model parameter performance	power supply CT6-EX05						
	DC12V	DC24V	DC220V	AC24V	AC110V	AC380V	AC220V
Motor Power	20W			15W			
Rated current	3.8A	2A	0.21A	2.2A	0.48A	0.15A	0.24A
Output torque	30Nm/50Nm			15Nm/30Nm/50Nm			
operation hours	6S / 10S			10S / 20S / 30S			
Control circuit	Type A, D type, G type, H type, K type, P type, R type, S type, intelligent non-intrusive and RS485 bus type						
Swing angle	0 - 360° adjustable						
Total Weight	6Kg						
Insulation resistance	100MΩ/300VDC			100MΩ/500VDC			
Pressure rating	500VAC/1 minute			1500VAC / 1 minute			
Protection level	IP67						
Ambient temperature	-25°C ~ +60°C (Other temperatures can be customized)						
installation angle	360° installation at any angle						
Carcass material	Aluminum alloy precision die casting						
Optional function	Heating dehumidifier						



EXCT6 - Angle stroke EX10/15 series dimensions and performance parameters

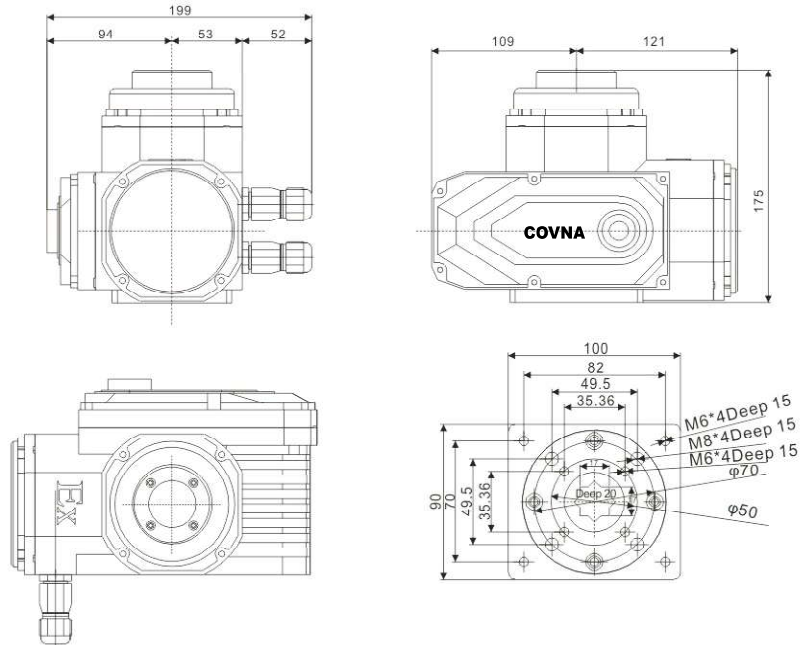

model parameter performance	CT6-EX10/15						
	DC12V	DC24V	DC220V	AC24V	AC110V	AC380V	AC220V
Motor Power	40W			25W/30W			
Rated current	4.8A	2.4A	0.32A	3A	0.64A	0.19A	0.32A
Output torque	100Nm			50Nm/60Nm/100Nm/150Nm			
operation hours	10S			13S/15S/20S/30S			
Control circuit	Type A, D type, G type, H type, K type, P type, R type, S type, intelligent non-intrusive and RS485 bus type						
Swing angle	0 ~ 360° adjustable						
Total Weight	8kg						
Insulation resistance	100MΩ/300VDC			100MΩ/500VDC			
Pressure rating	500VAC/1 minute			1500VAC / 1 minute			
Protection level	IP67						
Ambient temperature	-25°C ~ +60°C (Other temperatures can be customized)						
installation angle	360° installation at any angle						
Carcass material	Aluminum alloy precision die casting						
Optional function	Over-torque protection, heating dehumidifier						

EXCT6 - Angle stroke EX20/40/50/60/80 series dimensions and performance parameters

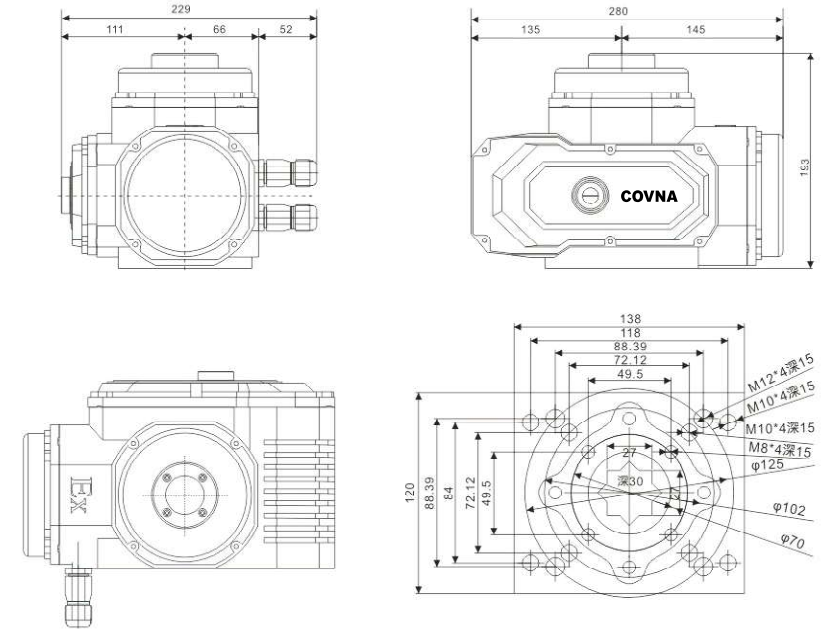

model parameter performance	CT6-EX20/40						CT6-EX50/60/80					
	DC24V	DC220V	AC24V	AC110V	AC380V	AC220V	DC24V	DC220V	AC24V	AC110V	AC380V	AC220V
Motor Power	40W/60W						90W/100W					
Rated current	8A	0.35A	5A	0.9A	0.25A	0.48A	7A	0.9A	8A	2A	0.45A	0.92A
Output torque	200Nm		200Nm/400Nm				500Nm/600Nm/800Nm					
operation hours	10S		15S/30S/60S				30S/30S/45S					
Control circuit	Type A, D type, G type, H type, K type, P type, R type, S type, intelligent non-intrusive and RS485 bus type											
Swing angle	0 ~ 90° adjustable											
Total Weight	13Kg						13Kg					
Insulation resistance	100MΩ/300VDC		100MΩ/500VDC				100MΩ/300VDC		100MΩ/500VDC			
Pressure rating	500VAC/1 minute		1500VAC / 1 minute				500VAC/1 minute		1500VAC / 1 minute			
Protection level	IP67											
Ambient temperature	-25°C ~ +60°C (Other temperatures can be customized)											
installation angle	360° installation at any angle											
Carcass material	Aluminum alloy precision die casting											
Optional function	Over-torque protection, heating dehumidifier											

EXCT6 Corner stroke EX100/200/300 series dimensions and performance parameters

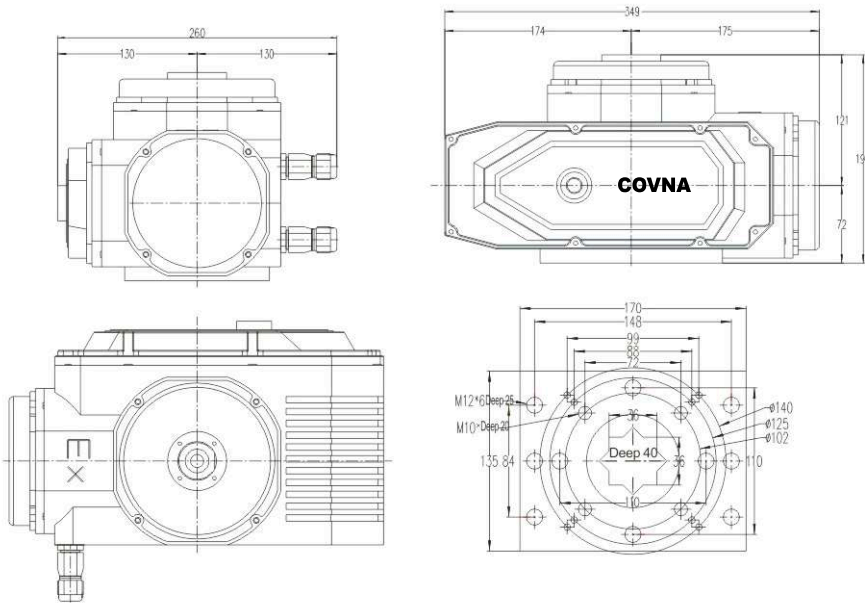

model power supply parameter performance	CT6-EX100				CT6-EX200/300			
	AC24V	AC110V	AC380V	AC220V	AC24V	AC110V	AC380V	AC220V
Motor Power	250W				250W			
Rated current	9A	2.2A	0.48A	1.2A	9A	2.2A	0.48A	1.2A
Output torque	300Nm/800Nm/1000Nm				2000Nm/3000Nm			
operation hours	30S				60S/90S			
Control circuit	Type A, D type, G type, H type, K type, P type, R type, S type, intelligent non-intrusive and RS485 bus type							
Swing angle	0 ~ 360° adjustable							
Total Weight	24Kg				24Kg			
Insulation resistance	100MΩ/500VDC							
Pressure rating	1500VAC / 1 minute							
Protection level	IP67							
Ambient temperature	-25℃ ~ +60℃ (Other temperatures can be customized)							
installation angle	360° installation at any angle							
Carcass material	Aluminum alloy precision die casting							
Optional function	Over-torque protection, heating dehumidifier							

EXCT6 Intelligent adjustment type (P type) performance parameters

model	05P	10P	20P	40P	50P	60P	80P	100P	200P	300P
power supply parameter	DC12V、DC24V、DC220V、AC24V、AC110V、AC220V、AC380V; 50/60Hz									
performance	DC12V、DC24V、DC220V、AC24V、AC110V、AC220V、AC380V; 50/60Hz									
Motor Power	15W	25W	40W	40W	90W	90W	90W	150W	250W	250W
Rated current	0.24A (AC220V)	0.32A (AC220V)	0.48A (AC220V)	0.48A (AC220V)	0.92A (AC220V)	0.92A (AC220V)	0.92A (AC220V)	1.0A (AC220V)	1.2A (AC220V)	1.2A (AC220V)
Output torque	50Nm	100Nm	200Nm	400Nm	500Nm	600Nm	800Nm	1000Nm	2000Nm	3000Nm
operation hours	30S	30S	30S	30S	30S	30S	45S	30S	60S	90S
Swing angle	0-90°	0-90°	0-90°	0-90°	0-90°	0-90°	0-90°	0-90°	0-90°	0-90°
Total Weight	7kg	8kg	13kg	13kg	13kg	13kg	13kg	24kg	24kg	24kg
input signal	4-20mADC, 1~5VDC, 0~10VDC (others can be selected before leaving the factory)									
output signal	4-20mADC (others can be selected before leaving the factory)									
Basic error	Not more than ± 1%									
Backlash	Less than 0.3%									
dead zone	Adjustable from 0.4% to 1.5%									
Damping characteristics	0 times									
Institutional repeatability error	0%									
Insulation resistance	DC24V: 100MΩ/300VDC					100MΩ/500VDC				
Pressure rating	DC24V: 500VAC / 1 minute					1500VAC / 1 minute				
Protection level	IP67									
Ambient temperature	25℃ ~ +60℃ (other temperatures can be customized)									
installation angle	360° installation at any angle									
Shell material	Aluminum alloy precision die casting									
Optional function	Over-torque protection, heated dehumidifier, passive contact type									



**First, the installation environment requirements**

1. This product can be installed indoors or outdoors.
2. in the long-term has the rain, the raw materials and so on spatter and the sunlight direct environment, needs to install the protective cover which protects the whole electric actuator;
3. please reserve the space needed for wiring, manual operation and other installation and maintenance;
4. Ambient temperature in the range of -30°C to 60°C.

Note: Use a model with a heating dehumidifier to prevent dewing when used in an environment with below zero or high temperature difference.

**Second, the working medium temperature requirements**

1. When used in conjunction with the valve, the temperature of the working medium reaches the top of the actuating mechanism, and the temperature of the actuating mechanism will rise;
2. the working medium is high temperature, and the bracket connected with the valve plays the role of reducing heat conduction;
3. Standard support shall be used when the working medium temperature is below 80°C;
4. the working medium temperature above 80°C, please choose the high temperature support.

**Third, the field cable line, wire and tube installation requirements**

1. There are two explosion-proof plugs at the inlet of the wiring compartment wiring. When wiring the user, one or two explosion-proof plugs should be removed according to the needs of use, and the explosion-proof joints suitable for the incoming cable should be installed. ≤14mm.
2. The power cable and signal cable should be introduced into the electric actuator from two explosion-proof joints respectively, and the grounding is required. In principle, the shielded wire should be used for the signal cable.
3. Remove the explosion-proof plug, install the explosion-proof joint that is compatible with the incoming cable, and tighten it.
4. As shown in Figure 2, unscrew the compression nut of the explosion-proof joint and thread the incoming cable from the sealant plug, compression nut and explosion-proof joint into the electric actuator.
5. Wiring according to the control circuit diagram.
6. Tighten the compression nut so that there is no gap between the sealing rubber plug and the cable.
7. The outer diameter of the incoming cable should be equal to the internal diameter of the explosion-proof connector. It is forbidden to use a single wire that does not meet the explosion-proof requirements.
8. The grounding of the internal and external parts of the actuator must be made.
9. This manual describes only one form of the explosion-proof cable splice. Users can also select other cables, connectors and wiring methods that meet the explosion-proof requirements.

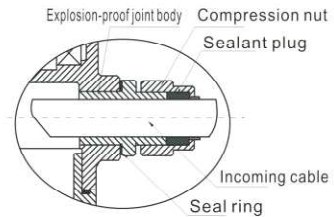

figure 2

**Fourth, the power requirements**

- (1) Providing the corresponding on-site power supply according to the type of power supply used for the type of the type of power ordered;
- (2) For the power supply and voltage of the power supply on site, the following requirements shall be met:

AC380V ± 10% 50/60Hz AC220V ± 10% 50/60Hz  
 AC110V ± 10% 50/60Hz AC24V ± 10% 50/60Hz  
 DC24V ± 5%

**Five, the choice of circuit breaker fuse**

model	Voltage							
	Resistor	AC380V	AC220V	AC110V	AC24V	DC220V	DC24V	DC12V
□-05		2A	2A	3A	5A	2A	5A	10A
□-10		2A	3A	5A	7A	3A	7A	14A
□-20/40/50/60		3A/5A	5A/7A	7A/10A	10A/11A	5A/7A	15A	
□-100/200/300		5A	7A	10A	20A	20A		

**First, the installation of actuators and valves (Figure 3)**

1. Manually turn the valve to determine the absence of the out-of-band condition and turn the valve to the fully closed position;
2. Gently fix the bracket to the valve with a bolt;
3. Place the electric actuator on the bracket and gently screw it with the bolt and nut;
4. Use the handle to drive the electric actuator to the fully closed position (the pointer points to the SHUT, 0 scale line), and fix the valve shaft core and the electric actuator output shaft with the coupling and the screw;
5. Tighten the screws between the electric actuator and the bracket;
6. Use the handle to drive the full stroke of the electric actuator to confirm that the operation is stable, no eccentricity, no skew, no jam, and check whether the valve can achieve full and full opening in the range of actuator opening indication.

Note: The force should not be too strong, otherwise it will cause the actuator to overrun and cause damage.

When installing, be careful to make the switch of the actuator match the switch of the valve. The flange at the bottom of the actuator complies with the ISO5211 standard. If the valve connected to it also meets this standard, it can be easily connected. If it does not meet this standard, an additional bracket connection is required.

**Special Note:**

For users who have their own brackets and couplings, please note:

1. Brackets and couplings should be designed and processed by professional technicians and should be in accordance with Labeling requirements for (Fig. 4);
2. The machining of the shaft holes at both ends of the coupling should ensure the necessary precision. Can eliminate the transmission gap, so as to avoid the return of the valve during operation;
3. should strictly guarantee the position of the shaft hole at both ends of the coupling, otherwise there is Can exceed the working range of the actuator design, resulting in the implementation of the machine The construction stroke cannot be adjusted and the valve does not work properly.

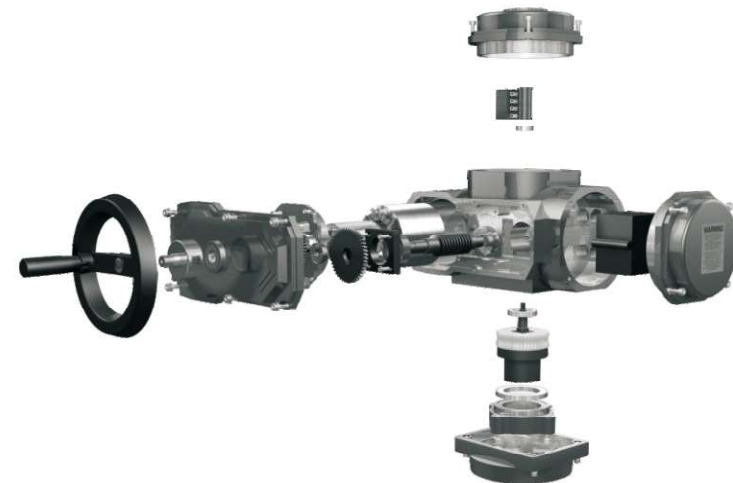

	<p align="center"><b>Ordinary switch type (type A)</b></p> <p>The valve is opened or closed by the switch circuit, and a set of indication valves are fully opened, Fully closed active position model.</p> <p><b>Wiring instructions:</b></p> <ol style="list-style-type: none"> <li>Terminal 1 is connected to the power supply neutral line;</li> <li>When the power phase line and terminal 2 are connected, it is "on" operation, and the stroke switch OLS is stopped;</li> <li>When the power phase line and terminal 3 are connected, it is "off" operation, and the travel switch CLS is stopped;</li> <li>When the power phase line is connected to the terminal 2 and the "on" operation is in place, the "full open signal" indicator connected to the terminal 4 is on;</li> <li>When the power phase line is connected to the terminal 3 and the "off" operation is in place, the "full off signal" indicator connected to the terminal 5 is on.</li> </ol>
	<p align="center"><b>Passive contact type (S type)</b></p> <p>The valve is opened or closed by the switch circuit, and a set of indication valves are fully opened, Fully closed passive position model.</p> <p><b>Wiring instructions:</b></p> <ol style="list-style-type: none"> <li>Terminal 1 is connected to the power supply neutral line;</li> <li>When the power phase line and terminal 2 are connected, it is "on" operation, and the stroke switch OLS is stopped;</li> <li>When the power phase line and terminal 3 are connected, it is "off" operation, and the travel switch CLS is stopped;</li> <li>Terminal 4 is a passive contact common end;</li> <li>When the "on" operation is in place, terminal 5 outputs a "full open signal";</li> <li>When the "off" operation is in place, terminal 6 outputs a "full off signal".</li> </ol>
	<p align="center"><b>Opening signal type (R type)</b></p> <p>The valve is opened or closed by the switch circuit, and the output corresponds to the opening position. Resistance signal.</p> <p><b>Wiring instructions:</b></p> <ol style="list-style-type: none"> <li>Terminal 1 is connected to the power supply neutral line;</li> <li>When the power phase line and terminal 2 are connected, it is "on" operation, and the stroke switch OLS is stopped;</li> <li>When the power phase line and terminal 3 are connected, it is "off" operation, and the travel switch CLS is stopped;</li> <li>Terminal 4 is the low end of the potentiometer. When "on" is running, the resistance between terminal 4 and terminal 5 increases as the valve opens;</li> <li>Terminal 5 is a potentiometer boom;</li> <li>Terminal 6 is the high end of potentiometer. When "off" is running, the resistance between terminal 5 and terminal 6 increases as the valve closes.</li> </ol>
	<p align="center"><b>With position transmitter (K type)</b></p> <p>The valve is opened or closed by the switch circuit, and the valve is opened and closed at the same time. Corresponding current signal. Output 4-20mA ADC valve position signal (for stroke position real-time feedback)</p> <p><b>Wiring instructions:</b></p> <ol style="list-style-type: none"> <li>The "N" of the power input terminal is zero line, and the "L" is connected to the phase line;</li> <li>When the "L" of the power input terminal is connected to "ON", it will run in the direction of valve opening;</li> <li>When the "L" of the power input terminal is connected to "OFF", it will run in the direction of closing the valve;</li> <li>The "+" at the "output signal" end is connected to the positive side of the output signal, and the "-" is connected to the output signal. The negative pole.</li> </ol>

Note: The inside of the dotted line in the control circuit is the internal circuit of the electric device, and the part other than the dotted line is only for reference when the user is wiring.  
 ⚠️ note! It is not possible to connect the power lines of two or several electric devices in parallel. It is not possible to use the same contact to control several electric devices. Otherwise, it will cause loss of control and overheating of the motor.

	<p align="center"><b>Intelligent adjustment type (P type)</b></p> <p>The opening and closing angle of the valve is controlled by a standard signal input from an external computer or an industrial instrument. And synchronous feedback output corresponding to the standard signal.</p> <p><b>Wiring instructions:</b></p> <ol style="list-style-type: none"> <li>The "N" of the "power" input terminal is connected to the neutral line, and the "L" is connected to the phase line;</li> <li>The "+" of the "external control" end is connected to the positive pole of the input signal, and the "-" is connected to the negative pole of the input signal;</li> <li>The "+" of the "feedback" end is connected to the positive pole of the output signal, and the "-" is connected to the negative pole of the output signal.</li> </ol>
	<p align="center"><b>DC switch type (D type)</b></p> <p>By switching the positive and negative poles of the external DC power supply, the "open" and "off" operation of the valve is achieved. At the same time, a set of passive contact signals indicating that the valve is fully open or fully closed is output.</p> <p><b>Wiring instructions:</b></p> <ol style="list-style-type: none"> <li>When terminal 1 is connected to the positive pole of the power supply, terminal 2 is connected to the negative pole of the power supply for "on" operation;</li> <li>When terminal 1 is connected to the negative pole of the power supply, terminal 2 is connected to the positive pole of the power supply for "off" operation;</li> <li>Terminal 4 is the common end of the passive contact;</li> <li>When the "on" operation is in place, terminal 5 outputs a "full open signal";</li> <li>When the "off" operation is in place, terminal 6 outputs a "full off signal".</li> </ol>
	<p align="center"><b>Three-phase switch type (G type)</b></p> <p>The valve is opened or closed by the switch circuit, and a set of indication valves are fully opened, Fully closed active position signal.</p> <p><b>Wiring instructions:</b></p> <ol style="list-style-type: none"> <li>Terminals 1, 2, and 3 are connected to three-phase AC power, and the motor is realized by an external inverter circuit. Positive and negative</li> <li>Terminal 4 is a common point of the external control circuit;</li> <li>Terminal 5 is "on" operation control;</li> <li>Terminal 6 is "off" operation control;</li> <li>When the "on" operation is in place, terminal 7 outputs "full open signal";</li> <li>When the "off" operation is in place, terminal 8 outputs a "full off signal".</li> </ol>
	<p align="center"><b>Three-phase passive contact type (H type)</b></p> <p>The valve is opened or closed by the switch circuit, and a set of indication valves are fully opened, Fully closed passive position signal.</p> <p><b>Wiring instructions:</b></p> <ol style="list-style-type: none"> <li>Terminals 1, 2, and 3 are connected to three-phase AC power, and the motor is realized by an external inverter circuit. Positive and negative</li> <li>Terminal 4 is a common point of the external control circuit;</li> <li>Terminal 5 is "on" operation control;</li> <li>Terminal 6 is "off" operation control;</li> <li>Terminal 7 is a passive contact common end;</li> <li>When the "on" operation is in place, terminal 8 outputs a "full open signal";</li> <li>When the "off" operation is in place, terminal 9 outputs a "full off signal".</li> </ol>

Note: The inside of the dotted line in the control circuit is the internal circuit of the electric device, and the part other than the dotted line is only for reference when the user is wiring.  
 ⚠️ note! It is not possible to connect the power lines of two or several electric devices in parallel. It is not possible to use the same contact to control several electric devices. Otherwise, it will cause loss of control and overheating of the motor.



## EXCT6 Electric machine commissioning

## EXCT6 Fine small multi-turn explosion-proof EXZ05/EXZ10/EXZ20/EXZ30

### 1. Adjustment of micro-adjustable electrical limit (Figure 5)

① Full-close adjustment: first use the handle to drive the valve to the full position, loosen the scale plate locking screw, adjust the scale plate, point the pointer to the tick mark 0 (SHUT direction), and tighten the scale plate locking screw. Then, the small screwdriver will adjust the closing adjustment axis S clockwise (Note: adjust the axis to press the unlocking adjustment), drive the stroke block D1 to rotate clockwise to trigger K2 and K1 to move and make a sound, and K1 will make a sound. Stop adjusting the closing adjustment axis S.

② Full open position adjustment: first use the handle to drive the valve to the full open position, so that the pointer points to the scale line 0 (OPEN direction) and then adjust the open position adjustment axis O counterclockwise with a small slotted screwdriver (Note: Adjust the shaft down pressure to unlock the adjustment), driving the travel stop D2 counterclockwise rotation triggers K4, K3 to operate in sequence and sounds, and stops adjusting the open adjustment axis O when K3 moves and makes a sound.

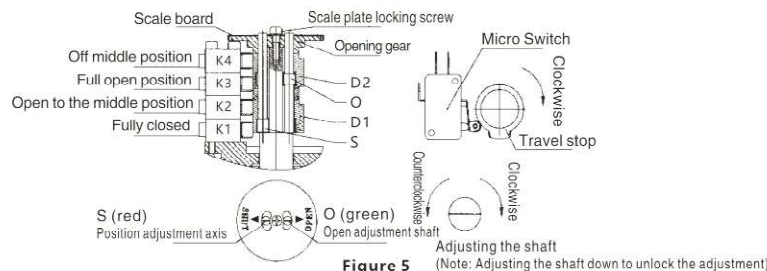

Figure 5

### 2. Adjustment of the electrical limit of the intermediate position model (Figure 6)

① D1 adjustment: Use the handle to drive the valve to the full position, loosen the scale plate locking screw, adjust the scale plate, point the pointer to the tick mark 0 (SHUT direction), and tighten the scale plate locking screw. Loosen the fixing screw on the stroke stop D1, turn the D1 clockwise and make the action sound just after the corresponding micro switch K1, stop the rotation D1 and lock the screw of D1 to fix the stroke stop D1.

② D2 adjustment: use the handle to drive the valve to the full open position, the pointer points to the tick mark 0 (OPEN direction), loosen the fixing screw on the travel stop D2, turn the D2 counterclockwise, and make it correspond to the corresponding micro switch K2. When the action sounds, stop turning D2 and tighten the screw of D2 to fix the stroke stop D2.

③ D3 adjustment: use the handle to drive the valve to the full open position, then use the handle to drive the valve clockwise to 2°, then release the fixed screw on the travel stop D3, turn the D3 counterclockwise, and make the K3 action Sound, then lock D3.

④ D4 adjustment: use the handle to drive the valve to the full position, then use the handle to drive the valve counterclockwise to open 2°, then release the fixing screw on the travel stop D4, turn the D4 clockwise, and make the K4 sound, then lock D4.

#### Special Note:

① After the user is equipped with the valve, if the full opening and full closing of the valve are inconsistent with the full opening and full closing of the electric execution, adjustment may be made, which can be carried out according to the method described in the above 1 or 2. ② "Off-to-center position" micro switch of the factory debugging is ahead of the "full-closed" micro-switch 2° action, "opening to the middle position" micro-switch is ahead of the "full-open" micro-switch 2° action, actual It can also be adjusted according to the control needs when using. When the middle micro switch is activated, the passive contact signal is output, and the fully closed and fully open micro switch operates to control the fully closed and fully open positions of the valve. Type A, C, E, and F machines have no intermediate position micro switch and life stop.

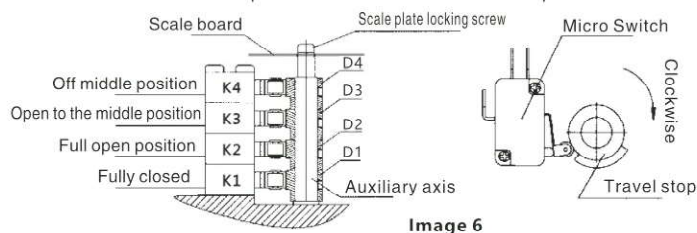

Image 6

### 1. Overview

The Z series multi-turn fine electric valve actuator is a new product that extends from the small-diameter gate valve and the stop valve. Changed the small-caliber electric valve to "big bully" situation. It is suitable for valves with linear motion of the opening and closing parts, such as small-diameter gate valves and small-diameter globe valves. Used for opening, closing or adjusting the valve. It is an indispensable driving device for remote control, centralized control and automatic control of valves. They have the features of full function, reliable performance, advanced control system, small size, light weight, convenient use and maintenance. Widely used in electric power, metallurgy, petroleum, chemical, paper, sewage treatment and other industries.

Z series multi-turn fine electric valve actuators are: switch type, passive type, opening type, electronic type, intelligent type and so on. According to the connection type, it is also divided into a torque type and a thrust type.

### 2. function and characteristics

1. Exquisite and compact, beautiful and elegant, the interior design is unique, and the toughness and wear resistance are not easy to damage;
2. small size: the volume is only about 35% of similar products;
3. light and cheap: the weight is equivalent to 1/3 of similar products;
4. beautiful and generous: die-cast aluminum alloy shell, the appearance is fine and smooth and can reduce electromagnetic interference;
5. the function is generous: switch type, passive contact type, proportional type, intelligent adjustment type have everything;
6. precision wear: worm gear and worm perfectly combined, harmonious linkage, worm gear output integration effectively reduces the connection
- The gap makes the transmission precision greatly improved;
7. easy to use: free inspection, no oil, rust and waterproof, installation at any angle;
8. multiple protection: electrical limit, mechanical limit, overheat protection, dehumidification protection;
9. CNC adjustment: highly integrated intelligent module, digital setting, digital setting, self-diagnosis highly accurate, no need for positioner, automatic control, multi-function;
10. security: through the AC1500V withstand voltage detection, H-class highly insulated motor, to ensure the body and production safety
11. Simple matching: single-phase, three-phase, DC power supply, simple external circuit

#### 2.1 intelligent features:

1. The intelligent electric actuator adopts integrated and modular technology, featuring reliable performance and complete functions. It integrates position feedback and servo amplification, and the adjustment is especially convenient. The wiring is especially simple and expandable. Communication Interface.
2. There are on-site digital display and manual operation functions: the actuator control module has a digital display that can display the actuator opening degree; and can perform on-site operation through the buttons on the control module.
3. there is a menu setting function: the intelligent control module has a menu setting button, through the menu button can be free to set the actuator control mode, control accuracy, protection measures.
4. Self-adjusting function: After the actuator electrical stroke (electrical zero position, full position) is determined, the actuator can automatically calibrate the electrical zero position and full-scale output without manual adjustment.

5. There are program setting upper and lower limit functions: the upper and lower limit strokes of the actuator can be set by pressing the button.
6. There is a break signal setting actuator action mode function: the actuator can select three states of full open, stop and fully closed under the condition of broken signal.
7. There is an actuator stall detection control function: the actuator is blocked, the control module disconnects the control output, and repeatedly detects the control, and blocks the rotation.
8. Electronic brake function: When the actuator needs to stop running, the control module outputs a reverse signal to realize the electronic brake.
9. there is over temperature protection function: control module ambient temperature  $\geq 70^{\circ}\text{C}$ , the actuator stops running.
10. There is automatic control function of actuator control: during the operation of the actuator, if there are more than 3 oscillations in succession, the control module will automatically reduce the positioning accuracy by 1/1000.
11. The motor has a thermal switch protection function: the thermal resistance switch is connected in series in the stator coil of the actuator. The motor temperature exceeds  $110^{\circ}\text{C}$ , the thermal protection switch operates, and the motor stops.
12. There is an error code indicating the fault function: When the actuator fails, the control module display shows an error code indicating the cause of the fault.

### 3. the main parameters

model	Z05 type	Z10 type	Z20 type	Z30 type
power supply	AC/DC24、AC/DC110V、AC/DC220V、AC/DC380V	AC/DC24、AC/DC110V、AC/DC220V、AC/DC380V		
performance	AC/DC24、AC/DC110V、AC/DC220V、AC/DC380V	AC/DC24、AC/DC110V、AC/DC220V、AC/DC380V		
Motor Power	0.10KW	0.25KW		
Torque	50N.M	100N.M	200N.M	300N.M
Output speed	5 (r/min)	18/24(r/min)	16(r/min)	8(r/min)
Circuit control	A、H、E、K、APtype			
Maximum stem diameter	20(mm)	28 (mm)		
Number of turns	50	50		
reference weight	14(Kg)	25(Kg)		
Pressure rating	1500VAC/min			
Insulation resistance	100m $\Omega$ /500V DC			
Protection level	IP67			
Ambient temperature	$-28^{\circ}\text{C} \sim 60^{\circ}\text{C}$ (other temperatures can be customized)			
installation angle	360° arbitrary angle			
Box material	Aluminum alloy die casting			
Work system	Short time 10 minutes (special custom 30 minutes)			

Note: The conventional power supply is 220V, 380V. If there are other technical requirements, please specify when ordering, the price is negotiable.

### 4. Z05Dimensions

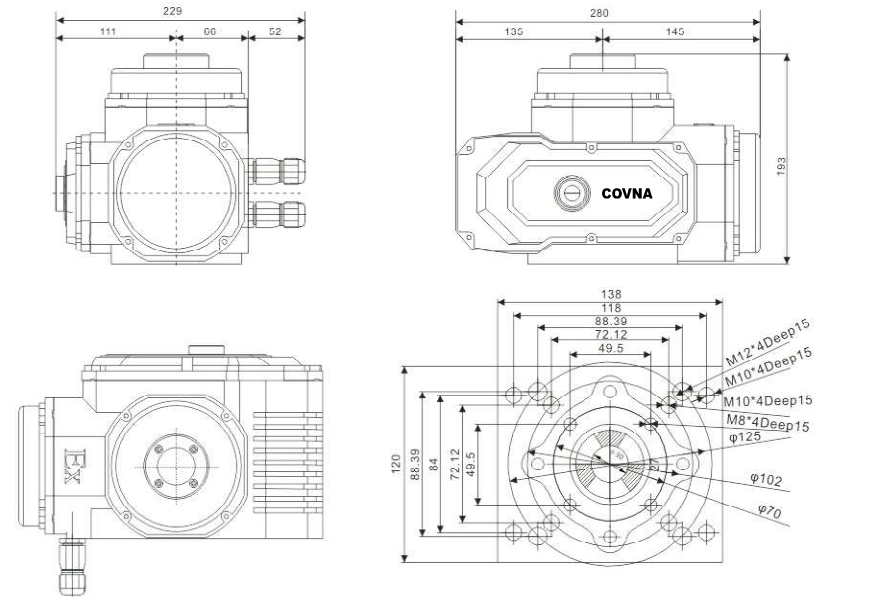

### Z10/Z20/Z30Dimensions

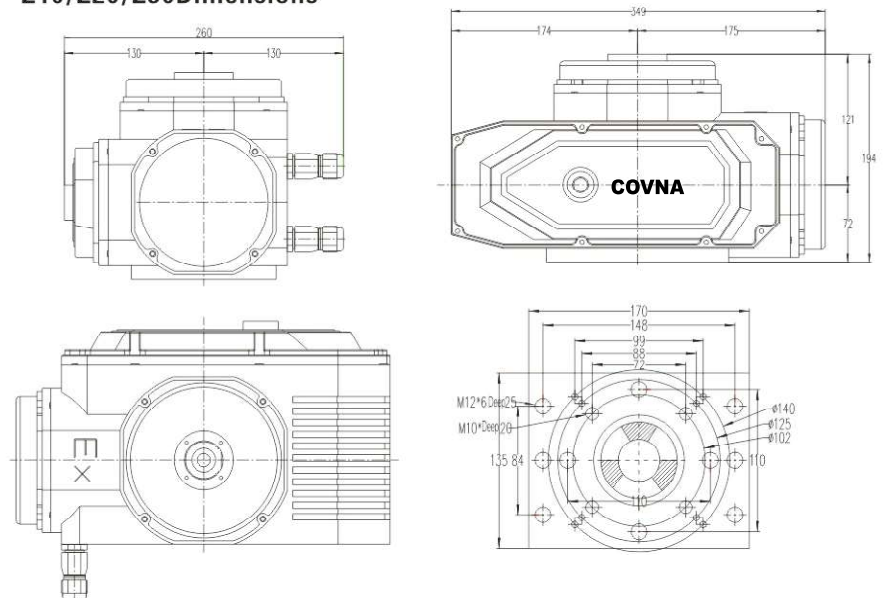



5. optional parameters

Electric device and gate valve matching table

Torque pressure	The way to												
	15	20	25	32	40	50	65	80	100	125	150	200	250
2.5	5	5	5	5	5	5	5	5	10	10	15	15	20
6	5	5	5	5	5	5	5	10	15	15	15	20	20
10	5	5	5	5	5	10	10	10	15	15	15	20	20
16	5	5	5	5	5	10	10	15	20	20	20	30	30
25	5	5	5	5	5	10	10	15	20	20	20	30	30
40	5	5	5	5	5	10	10	15	20	20	30	30	45
64	5	5	5	5	10	10	10	20	20	30	30	60	90
100	5	5	5	10	10	15	20	20	30	45	60	90	120
160	5	10	10	15	15	20	20	30	30	60	90	120	
320	10	10	10	15	20	20	45	60	90				

Knife type gate valve and valve matching table

The way to	50	65	80	100	125	150	200	250	300
Torque	10	10	10	10	10	15	20	20	30

Electric device and globe valve selection table

Torque pressure	The way to												
	15	20	25	32	40	50	65	80	100	125	150	200	250
10	5	5	5	5	5	5	5	10	15	20	30	45	60
16	5	5	5	5	5	5	10	20	20	30	45	60	120
25	5	5	5	5	5	10	10	20	20	30	60	60	180
40	5	5	5	5	5	10	10	20	30	45	120	90	
64	5	5	5	5	10	10	20	30	45	90	180		
100	5	5	5	10	10	20	30	45	60	120			
160	5	10	10	20	30	30	45	90	120	180			
320	5	10	20	30	45	45	90	120	250	500			

6. Schematic diagram of the structure of the mouth

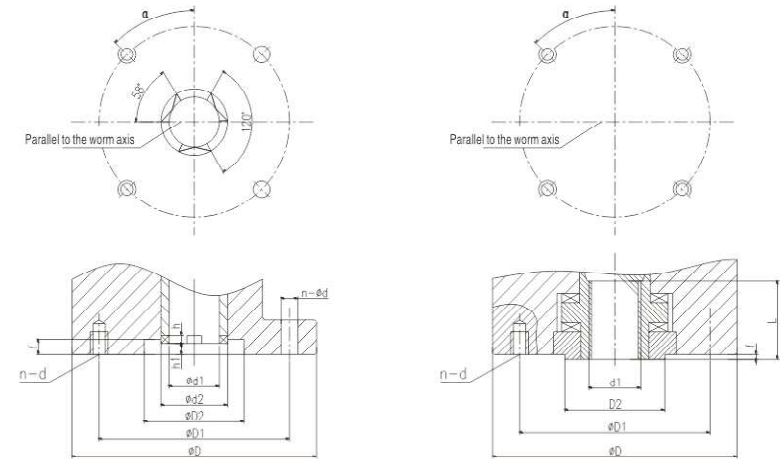

Torque type connection dimensions are shown in Figure 2 and Table 3.

Thrust type connection dimensions are shown in Figure 3 and Table 4.

Table 3 Torque type connection size

model	Torque type JB2920											
	Flange number	D	D1	D2 (H9)	h1	f	h	d1	d2	d	n	α
BYS-Z05	2I	125	102	0	0	0	8	30	45	M10	4	45°
BYS-Z10	2	145	120	90	2	4	8	30	45	M10		
BYS-Z20	2I	125	102	0	0	0	8	30	45	M10	4	45°
BYS-Z30	2	145	120	90	2	4	8	30	45	M10		

Table 4 Thrust type connection size

model	Thrust type GB12222									
	Flange number	D	D1	D2 (f8)	f	d1max	d	L	n	α
BYS-Z□05	F10	125	102	70	3	T28	M10	40	4	45°
BYS-Z□10	F10	125	102	70	3	T28	M10	40	4	45°
BYS-Z□20	F10	125	102	70	3	T28	M10	40	4	45°
BYS-Z□30	F10	125	102	70	3	T28	M10	40	4	45°

## 7. the trip control mechanism

The principle of decimal counter is adopted, and the control precision is high. For the full range of common components, the structure is shown in Figure 6. The working principle is as follows: a pair of large and small bevel gears in the reduction gear box drive the driving pinion (Z=8), and then drive the stroke controller to work. If the stroke controller has been adjusted according to the position where the valve is opened and closed, when the controller rotates to the pre-adjusted position (number of turns) with the input shaft, the cam will rotate 90°, forcing the micro switch to operate and cutting off the motor. The power supply stops the motor and controls the electric actuator stroke (number of revolutions).

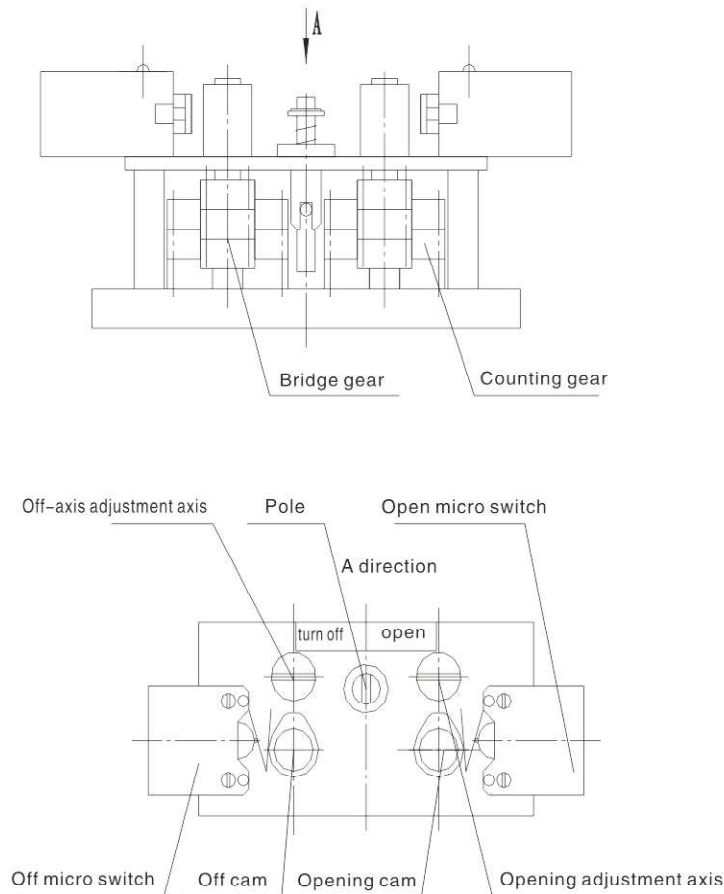

## Safety Precautions

To ensure your safe use, to protect yourself and the surrounding people from harm and damage to the property in your work area, please read this note:

1. Check if the special equipment is reserved for you.
2. The commissioning, installation and maintenance of the products require professional operation.
3. This product is non-explosive type. Do not use it in the case of explosive gas.
4. When changing the use of the product, please consult the sales person in charge of the company in advance.
5. This product is manufactured under strict quality control. However, when it is used for important equipment, if some equipment failure may cause a major accident, safety equipment should be installed on the equipment.
6. Safety matters that should be paid attention to during general operation:
  - (1) Non-professionals should not disassemble themselves due to the possibility of electric shock, fire, injury, etc.
  - (2) Do not put any items into the movement range of the self-adjusting actuator.
  - (3) If liquid such as water invades the self-regulating actuator, immediately turn off the power and notify the professional to repair it.
  - (4) If there is smoke, odor, strange noise, etc. in the self-adjusting actuator, immediately turn off the power and notify the professional to repair.
  - (5) Turn off the power when not in use for a long time.

## Use and maintenance of electric actuators

1. The electric actuator should be inspected, inspected and commissioned according to the methods specified in this manual before use.
2. Before the electric actuator is put into operation, it should check whether the power supply voltage of the site is consistent, and at the same time, according to the specified electrical Install the wiring diagram to check that all wiring is correct and reliable.
3. The connection between the output shaft and the adjustment mechanism must not be loose to ensure good adjustment.
4. the actuator on-site machine operation can be operated under power-on conditions, the operating handle must be the special accessories provided by the company Otherwise it is easy to damage the actuator.
5. The output force of the electric actuator should be compatible with the load.
6. The components of the electric actuator should be inspected and adjusted regularly according to the conditions of use on site. The reducer should be cleaned regularly. Add the appropriate grease. In normal case, clean it once every two years. It should be cleaned once a year in bad conditions. Run The slip grade is the imported extreme lithium complex grease (Iron Pa Green Grease).
7. If the electric actuator fails, it should be eliminated in time. Otherwise, the power supply of the actuator should be cut off to avoid production.Born a bigger fault.
8. During the transportation, the actuator should avoid rain and water, and the ambient temperature should not exceed 60°. Pay attention to transportation, thousands10,000 can not be artificially impacted, falling, so as not to damage the instrument.
9. The electric actuator should be stored in a dry, ventilated, non-corrosive gas warehouse for no more than one and a half years.



8. control circuit diagram

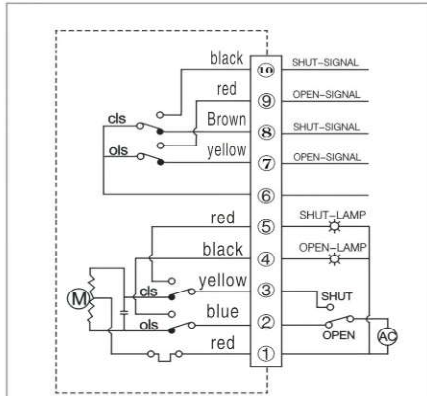

Type A

**Type A:** Limit position switch (AC220V standard type)  
**Function:** open and close operation through the switch circuit. Output a set of active position signals (full open, fully closed) and output a set of passive electric shock (normally open, normally closed) signal

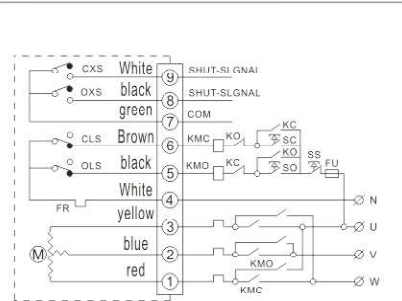

Three-phase passive contact type (H type)

The valve is opened or closed by a switching circuit, and a set of passive position signals indicating that the valve is fully open and fully closed is output.

**Wiring instructions:**

1. Terminals 1, 2, and 3 are connected to three-phase AC power, and the motor is reversed and reversed by an external inverter circuit;
2. Terminal 4 is a common point of the external control circuit;
3. Terminal 5 is "on" operation control;
4. Terminal 6 is "off" operation control;
5. Terminal 7 is a passive contact common end;
6. When the "on" operation is in place, terminal 8 outputs "full open signal";
7. When the "off" operation is in place, terminal 9 outputs a "full off signal".

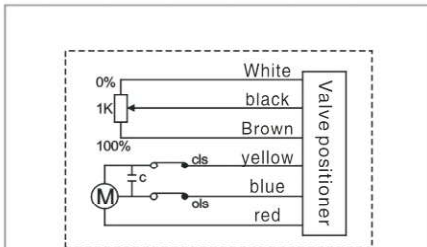

Type E

**Type E:** with intelligent servo controller (regulator)  
**Function:** adjustment function, input 4-20MADC, 0-10VDC, Or 1-5VDC, output 4-20MADC.  
**Structure:** with intelligent servo controller and 1kΩ, 5kΩ potentiometer

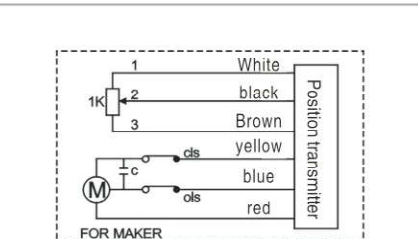

H type

**K type: with R / I converter**

**Function:** Output 4-20MADC valve position signal (for valve realization Full feedback)  
**Structure:** with R / I converter and 1kΩ potentiometer

Ap type: overall adjustment type (AP type)

V1kit fine small three-phase terminal board wiring diagram

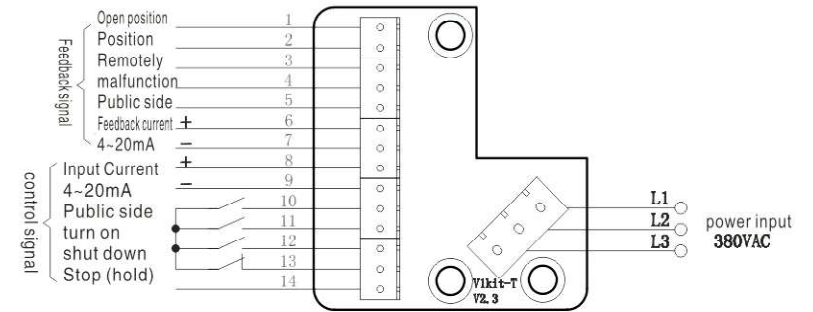

V1kit fine small single-phase terminal board wiring diagram

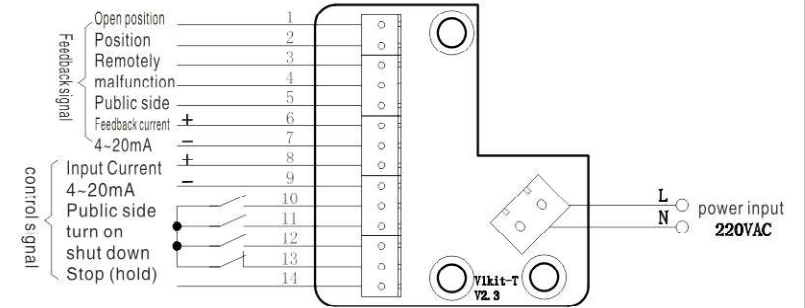

### 9. product overview

This product is a smart non-invasive electric actuator. LCD display, infrared remote control operation, self-diagnosis fault alarm. The local operation adopts non-contact sensing components without opening and debugging, simple and durable; the position detection adopts advanced absolute encoder, no dead zone, the encoder position control is accurate, no need to use the limit switch limit; the motor drive has AC contactor drive Type (relay output, drive AC contactor coil) and motor direct drive type (SCR direct drive three-phase or single-phase motor); this product combines a number of independent research and development of innovative high-tech, with complete advanced features, reliable stability and cost-effective advantages. Easy to debug, easy to install and easy to set up.

### 10. technical parameters

- Working voltage range: three phases: 380VAC. Range: 340VAC~420VAC; Single phase: 220VAC. Range: 220VAC~240VAC; Other input voltages can be ordered separately.
- Operating temperature range: -20 °C ~ 70 °C; storage temperature range: -40 °C ~ 85 °C.
- the use of humidity range: ≤ 90% RH, no condensation, surrounded by strong corrosive, flammable and explosive gases or dust.
- analog signal feedback: feedback current valve opening signal, conventional DC4 ~ 20mA current signal, load capacity ≤ 750 Ω .
- switch signal feedback: can feedback 4 sets of relay switch signals. They are remote state, fault state, open in place and closed in place.
- analog signal input: detection input opening signal, conventional DC4 ~ 20mA current signal, internal load size 195 Ω .
- switch signal input: passive dry contact input, built-in 24V DC power supply, the common terminal is 24V+. Detect remote control signals such as open, close, and hold.
- Signal isolation of each channel: Each input and output terminal is isolated by relay and optocoupler and can withstand 2000V surge voltage.
- drive signal output: relay or thyristor output is optional. Applicable to reversible control, the on-duration rate is 50%, and the number of times per hour is ≤ 1200 times.

### 11. the main components

The control unit man-machine interface includes three components: a liquid crystal display, a position selection knob and an operation knob.

- valve opening and parameter type  
That is, the current percentage of the valve opening (in the normal state);  
When zeroing and fulling, the characters "LL" and "HH" are displayed; when the feedback current is adjusted, the characters 4mA"LF" and 20mA "HF" are displayed;  
When the input is 4mA and 20mA, the characters "04" and "20" are displayed.
- control mode  
In the live state, the characters "bc" (hold) and "dd" (jog) are displayed;  
In the remote state, the adjustment type displays the character "Cxx", indicating that there is input current. Display the character "C--", indicating "loss of trust";

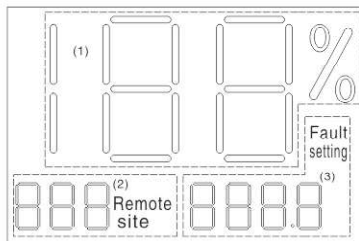

figure 1

In the remote state, the switch type, there is no remote signal, no display; there is a remote open signal, display "OP", there is a remote off signal display "CL". There is a remote hold signal, displaying "bc", and vice versa showing "dd" (multiple states, alternate display);  
In the stop state, when the remote controller is used to enter the setting state, the character "Pxx" is displayed, indicating the set parameter label, counting from 0;  
In the stop state, in the non-set state, the character "xxx" is displayed, the first character: 1 indicates a single-turn encoder, and 2 indicates a multi-turn encoder;  
The second character; 1 indicates the contactor output, 2 indicates the thyristor output; the third character; 1 indicates the adjustment type, and 2 indicates the switch type. (only more The rotary actuator has this display)  
Note: Infrared remote control must be used to enter the setup state !!

### 3, valve status

When there is a fault, the character "Exx" is displayed, and the fault code is displayed;  
When there is no fault, the display character "bxxx" shows the true reading of the encoder.  
Reduce the value after N times (0-255);  
The two knobs of the control unit are shown in Figure 2, operating the knob (black),  
Position knob (red).  
4, the operating knob has two positions: closed, open;  
5. The position knob has three positions: on-site, stop, and remote.

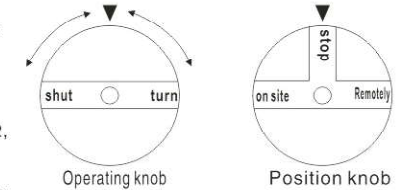

figure 2

### 12. control unit operation instructions

#### 1. Field operationIn

the field position, the operation knob is turned on or off for 3 seconds, and the field control mode is changed from point motion (dd) to hold (bc); the direction operation spin is operated. Knob or position knob to stop, that is, stop action.

#### 2. Remote control operation (remote control is optional)

The control unit can use the remote control for field operation or parameter setting. The infrared remote controller has 6 operation keys. The functions of each key are as follows: Open the key (add the key). In the field operation, it can be used as an open button. When entering the parameter setting, it is used as an add key, and the set number is set every time you press it. Increase once; (2) Turn off the keys (reduce the keys). In the field operation, it can be used as the closing button. When entering the parameter setting, it is used as a reduction key, and is set every time it is pressed. Reduce the number once; (3) Setting the key to determine. In the stop position, press this key for a long time to enter the parameter setting state. In the menu setting state, click again to enter the next menu. (4) Stop key (return key). In the field operation, it can be used as a stop button. In the menu setting state, Click to return to the previous menu. \_Up key. In the menu setting state, the parameters can be adjusted. \_Push down the key. In the menu setting state, the parameters can be adjusted.

#### 3. Position Calibration

After the electric actuator and the valve are connected, the steering of the electric actuator is determined first. Correct connection with torque, adjust the best rotation angle of encoder (generally large) At 90 degrees, the valve position can be calibrated without opening the cover. The specific methods are as follows:

#### 3.1. Calibration clearance

The first step is to enter the calibration clearance. Under stop position, operate knob to Close for about 5 seconds until the flickering character "LL". Half of the screen flickers "LL"; the lower left corner shows the horizontal line; the lower right corner shows the value of the encoder (0-255).

The second step is to adjust the valve position. Position knob is rotated to the spot position and used. Make knob or remote control to open key (1) and close key (2) to adjust valve position arbitrarily. The critical position (not limited by the original calibrated full-on and full-off position).  
Valve closure After adjustment, the position knob is turned

to stop position, and the position calibration can be continued. Note: If the valve is fully closed, the second step can be omitted and jumped directly. Step 3.

The third step is to determine the calibration clearance. Valve closing is adjusted and position knob is turned To the stop position, the operation knob is turned off to determine that the position is marked as the whole clearance. When the calibration is successful, "LL" no longer flickers. After fixing the display of "LL" for 3 seconds, it exits the calibration clearance and returns to the normal display interface.

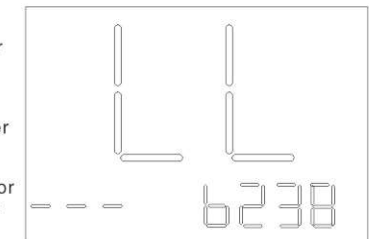
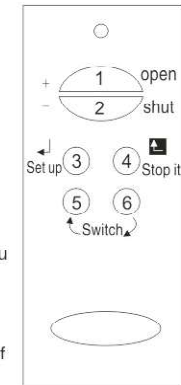

figure 3



Note 1: Because of the direction of the encoder or valve installation, when the valve is opened, the encoder reading may increase continuously or possibly. Continuous reduction, in order to ensure the correct opening display, the control system has an automatic learning function, in the position calibration, the use of electric mode. Continuous opening or closing of the valve for more than 5 seconds can automatically learn the direction of the encoder.

**3.2. Open calibration in the stop position**

the operation knob is turned on for about 5 seconds until the flash refining character "HF". Enter all calibration settings. operationThe method is basically the same as the calibration clearance (different from the calibration clearance: the operation knob is turned on once to confirm the full opening).

**4. Feedback Current Correction Note:**

When the feedback current is corrected, the position knob is turned to the "remote" state, when there is a signal in the DCS room, which may lead to the actuator. Error action should be performed in case of remote message loss.

**4.1. Feedback 4mA Amendment**

① adjust the valve to the fully closed position. In remote location, operateThe knob is turned off for about 5 seconds until the flickering character "LF". Half of the screenPartial flicker "LF"; display remote information in the lower corner, adjustable displayCurrent, "Cxx". Switch mode shows whether there is a remote switch signal. The lower right corner shows the value of the encoder (0-255).

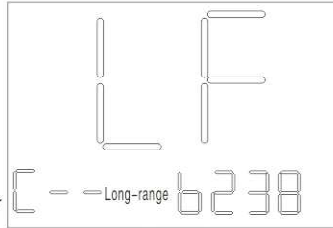

figure 4

② According to the value of 4 mA feedback current, the operation knob can be used to correct the current (turn on). One turn, one increase in current, one turn off, and one decrease in current. It can also be adjusted by the remote controller '+/-button'. After the current correction is completed, The position knob leaves the remote position, exits the modified 4mA interface and returns to the normal display interface.

2. Feedback 20mA AmendmentFirst, adjust the valve to the full open position. In the remote position, the operation knob is turned on for about 5 seconds until the flickering character "HF". Enter the revised 20mA settings. The method of operation is completely consistent with the feedback 4mA correction.

**13. Internal control parameter setting (remote control is required to enter setting menu)**

In the stop state, you can enter the menu by pressing the setting button of the remote controller for 5 seconds. Setting internal control parameters. Setting order of internal control parametersFor:

1. Input 4mA correction, 2. Input 20mA correction, 3. Close direction.4. Location of letter loss.1. Input 4mA calibration (calibration range: 3.8-4.5mA)After entering the menu, the first internal control parameter is displayed. The display interface is shown in Figure 5."04" flickers in the half of the screen; internal control parameters are displayed in the lower left corner. The label is "P00". The lower right corner shows "NO". At this point, the standard 4mA control current is input to the control unit, and it is set for several seconds. After stabilization, pressing the down key of the remote control can be changed from "NO" to "YES". Press the remote control confirmation key to confirm that the current input current is 0%. Location. If the settings are successful, "LF" no longer flickers, fixed display "LF" 3 seconds later, automatically jump to the next control parameter; if not setSuccessfully, automatically jump to the next control parameter.

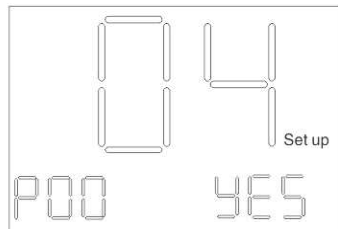

figure 5

2. Input 20mA calibration (calibration range: 18.5-21.5mA)The operation method is exactly the same as the input 4mA calibration.

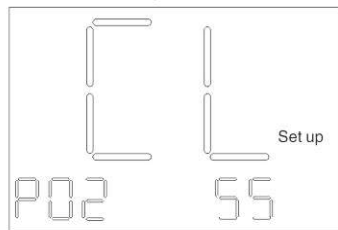

figure 6

3. Close direction (default: clockwise)The display interface in the direction of closure is shown in Figure 6:"CL" is displayed in the half of the screen, and internal control parameters are displayed in the lower left corner. The label "P02"; the lower right corner shows "sS" (clockwise Pinyin). Abbreviations) and "nS" (anti-clockwise Pinyin abbreviation). At this point, the "sS" and "nS" are performed by the up and down keys of the remote control. "NS" switch, after modification, press the setting key of the remote control to confirm.

4, lost position (only adjustable type has this function, default position: hd)

The display interface of the lost position is shown in Figure 7:

The upper part of the screen displays "LS"; the lower left corner shows the internal control parameters. The label "P03"; the lower right corner shows "hd" (a total of "0", "50", "100", "hd" four positions, corresponding to "full off", "middle Bit", "full open" and "hold" can now be passed through the remote control Shift key and down shift key are in "0", "50", "100", "hd" Switch between, modify it, press the remote control's setup button to confirm, and drop out.

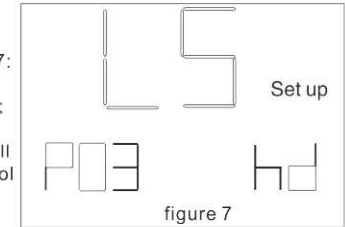

figure 7

**14. fault code and diagnosis**

When a fault occurs, the character "Exx" is displayed in the lower right corner of the screen, where xx indicates the fault number. This control unit has a fault diagnosis function. The main faults and protections are shown in the following table:

Fault code	Fault type	Condition	Reset condition	Remarks
E01	Power supply phase loss	Three-phase power supply lacks one phase	Cannot be automatically reset unless power is turned off	Can't switch
E02	Thermal Protection	Motor Temperature Switch Disconnected or Torque Common End Opened	Wait until the motor temperature drops to the appropriate temperature	Can't switch
E05	Valve position failure	Unreadable encoder signal	Encoder is properly connected	Single and multiple circles
E06	Encoder failure	Valve position unchanged due to blockage or other reasons	Automatic recovery after encoder digital changes	Valve stuck or encoder tripped
E12	Open to the moment	Opening Torque Switch Action when Opening Valve	Torque switch reset, perform reverse operation, or switch to remote mode	In case of failure, only the valve can not be opened
E16	Off-axis	When dosing the valve, turn-off moment switch action	Torque switch reset, perform reverse operation, or switch to remote mode	In case of failure, only the valve can not be closed
E17	Encoder corner is too large	Long journey	Automatically cleared, the fault disappears automatically after 3s	Recalibrate the itinerary
E18	Encoder corner is too small	Over 1 lap for short trip or single-loop encoder	Automatically cleared, the fault disappears automatically after 3s	Recalibrate the itinerary

**15. common problem handling methods**

Power-on indicator and display do not display	A. The power supply is not actually connected to B. The voltage is too low C. The connection is wrong D. The circuit is bad.
Lamp and display show abnormality during work	A. Failure Code B. Replacement of Circuit if Indicator or Display is Bad
Power on site and remote control are not active	A. Faulty wiring or open circuit B. Fault protection C. Motor failure or jam D. Start capacitor failure E. Circuit failure
The site works normally but the remote control does not work.	A. No signal or wiring back B. The knob board is bad or not far away C. Positive/Reactive setting error D. Circuit is bad.
The scene does not move but the remote control works normally.	A. Knob not in site mode B. Operating knob not in place C. Circuit failure
Can not open or can not be opened	A. Torque wiring error or open circuit B. Over-torque fault C. Motor failure or blockage or wiring error D. Circuit failure
No control signal is energized immediately	A. Connection Error B. Control Signal Actually Effective C. Loss Action Position Error D. Circuit Bad
Action direction	A. Motor wiring inversion B. Valve position calibration inversion C. Closing direction inversion D. Signal inversion
No output current	A. Output wiring error or poor contact B. Circuit failure
Feedback current is too large or too small or constant	A. Feedback Current Not Corrected B. Circuit Bad

### 16. safety precautions

To ensure your safe use, to protect yourself and the surrounding people from harm and damage to the property in your work area,

Please read this note:

1. Check if the special equipment is reserved for you.
2. The commissioning, installation and maintenance of the products require professional operation.
3. This product is non-explosive type. Do not use it in the case of explosive gas.
4. When changing the use of the product, please consult the sales person in charge of the company in advance.
5. This product is manufactured under strict quality control, but when used in important equipment, such as some equipment failure may lead to

In the event of a major accident, a safety device should be installed on the equipment.

6. Safety matters that should be paid attention to during general operation:

- (1) Non-professionals should not disassemble themselves due to the possibility of electric shock, fire, injury, etc.
- (2) Do not put any items into the movement range of the self-adjusting actuator.
- (3) If liquid such as water invades the self-regulating actuator, immediately turn off the power and notify the professional to repair it.
- (4) If there is smoke, odor, strange noise, etc. in the self-adjusting actuator, immediately turn off the power and notify the professional to repair.
- (5) Turn off the power when not in use for a long time.

### 17. Use and maintenance of electric actuators

1 Electric actuators should be inspected, inspected and commissioned according to the methods specified in this manual before use.

2 Before the electric actuator is put into operation, it should be checked whether the power supply voltage at the site is in accordance with the specified requirements, and at the same time according to the specified electrical

Install the wiring diagram to check that all wiring is correct and reliable.

3 The output shaft and the adjustment mechanism must not be loose at all connections to ensure good adjustment.

4 Actuator local robot operation can be operated under power, the operating handle must be the special accessories provided by the company  
Otherwise it is easy to damage the actuator.

5 The output force of the electric actuator should be compatible with the load.

6 The components of the electric actuator shall be inspected and adjusted regularly according to the conditions of use on site, and the reducer shall be cleaned regularly.

Add the appropriate grease. In normal case, clean it once every two years. It should be cleaned once a year in bad conditions. Run

The slip grade is the imported extreme lithium complex grease (Iron Pa Green Grease).

7 If the electric actuator fails, it should be eliminated in time. Otherwise, the power supply of the actuator should be cut off to avoid production.

Born a bigger fault.

8 During the transportation, the actuator should avoid rain and water, and the ambient temperature should not exceed 60°. Pay attention to transportation, thousands

10,000 can not be artificially impacted, falling, so as not to damage the instrument.

9 Electric actuators should be stored in a dry, ventilated, non-corrosive gas warehouse for no more than one and a half years.